

SKID STEER

ALL-NEW 2056



mustangmfg.com



2056

This new breed of Mustang skid steer is the perfect combination of size and power. A width under 60 inches with optional narrow tire set allows for easy maneuverability on sidewalks and narrow paths. A rated operating capacity of 2,050 pounds with optional counterweight provides raw strength for the toughest tasks.





PERFORMANCE

HIGH-REACHING RADIAL-LIFT DESIGN – Lift heights up to 122 inches with 12.00 tires or 120 inches with 10.00 tires.

SOLID WORKHORSE – Powered by a 62-hp Deutz Tier III-certified turbocharged diesel engine, this machine provides extra power when needed and smooth, quiet operation.

FULLY LOADED – Rated operating loads of 1,900 pounds, or 2,050 pounds with optional counterweight, make a powerful dent in your workload.

HIGH-FLOW AUXILIARY HYDRAULICS – Up to 30 gallons per minute for applications that demand maximum performance.

SMOOTH OPERATOR – Standard Hydraglide™ ride control system allows the load arm to float while travelling, reducing the amount of spilled material and providing smoother operation.

FIRST-CLASS COMFORT

EXCELLENT VISIBILITY – Good visibility to the rear tires and an open-front design provides better visibility to the front of the loader.

CONTROLLED ENVIRONMENT – Complete cab enclosure is available with air-conditioning and heater. Sound suppression materials reduce cab noise levels for added comfort.

GET IN CONTROL – Standard joystick controls with adjustable towers for supreme operator comfort.

INFORMATION AT-A-GLANCE – Eye level instrumentation reduces fatigue.



SERVICEABILITY AND SAFETY

TILT-BACK ROPS – Quickly reveals internal components for faster and easier maintenance and service.

EASY ACCESS – Large engine cover is hinged and positioned by gas-springs to assist in lifting and holding the cover in place for easy, safe maintenance.

SAFETY FIRST – Safety Interlock System ensures that the operator is in the seat with the restraint bar down before the engine will start, as well as prevents drive or hydraulic functioning.

2056 SPECIFICATIONS AND FEATURES

DIMENSIONS	A. Overall Operating Height – Fully Raised (mm)	160" (4064)
	B. Height to Hinge Pin – Fully Raised (mm)	120.7" (3066)
	C. Overall Height to Top of ROPS (mm)	78.0" (1981)
	D. Ground Clearance to Chassis	7.5" (191)
	E. Overall Length with 66" Bucket (mm)	126.3" (3208)
	F. Overall Length without Bucket (mm)	94.2" (2393)
	G. Wheelbase (mm)	42" (1067)
	H. Dump Reach at Full Height (mm)	23.1" (587)
	I. Bucket Rollback at Ground	23°
	J. Dump Angle	43°
	K. Overall Width (mm)	62"/59.7" ^A (1575/1516) ^A
	L. Bucket Width (mm)	60" - 75" (1524-1905)
	M. Clearance Circle - Rear (mm)	58" (1473)
	N. Clearance Circle - Front without Bucket (mm)	45" (1143)
	O. Clearance Circle - Front with Bucket (mm)	79" (2006)
	P. Seat to Ground Height (mm)	39.7" (1008)
	Q. Rollback at Full Height	91°
	R. Dump Height (mm)	90" (2286)
	S. Departure Angle	25°
Standard Specification Tire Size	10.00 x 16.5 HD	
ENGINE	Make	Deutz
	Model	TD2009
	Net Power (kW) @ 2500 rpm	62 hp (46)
	Displacement (L)	140 cu. in. (2.3)
HYDRAULIC SYSTEM	Auxiliary Hydraulics – Standard (L/min)	19 gpm (72)
	High-Flow Hydraulics – Optional (L/min)	30 gpm (114)
	Filtration	3 micron
	Reservoir Capacity (L)	12 gal. (45)
CAPACITIES / WEIGHT	Rated Operating Capacity ^B (kg)	1900 lbs. (862)
	Rated Operating Capacity w/ Opt. Counterweight ^B (kg)	2050 lbs. (930)
	Tipping Load ^B (kg)	3800 lbs. (1724)
	Fuel Tank (L)	16 gal. (60)
	Travel Speed – Maximum (km/hr)	7.7 mph (12)
	Travel Speed – Two-Speed Option (km/hr)	12.4 mph (20)
Operating Weight ^C - Approximate (kg)	6,800 lbs. (3084)	

- A Narrow width with narrow off-set wheel option
 B Per SAE J818, SAE J732, and ISO 14397
 C Weight of base unit with standard equipment, standard tire (heavy-duty flotation), standard (dirt-construction) bucket and 175 lb. (79 kg) operator

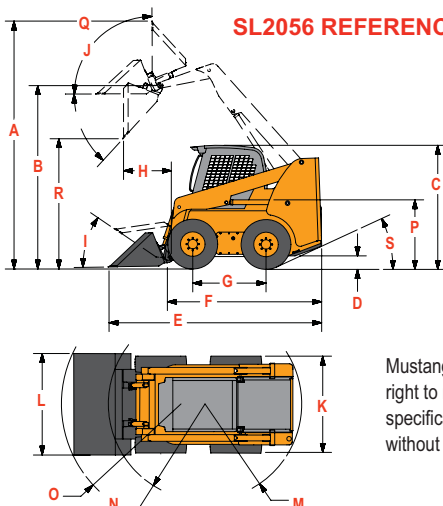

Mustang reserves the right to make changes in specifications at any time without notice or obligation.

FEATURES	2056
PILOT CONTROLS	
Joystick Controls	●
ENGINE	
Engine Auto-Shutdown System	●
Engine Pre-heater – Auto	●
Turbocharged Engine	●
HYDRAULICS	
Auxiliary Hydraulics	●
High-Flow Auxiliary Hydraulics	●
Independent Hydraulic Reservoir	●
OPERATOR STATION	
Air-Conditioning	●
Cab Enclosure	●
Foot and Hand Throttles	●
Full Instrumentation	●
Heating	●
Horn	●
Integral Access Plate (removeable)	●
Operator Restraint Bar with Padded Armrests/Seat Belt	●
ROPS/FOPS Level II Overhead Guard with Integral Side Screens	●
Sound Reduction Material	●
Suspension Seat – Mechanical	●
Work Lights - Front and Rear	●
PERFORMANCE	
Multi-Tach [®] Attachment Mounting	●
Anti-Vandalism Protection	●
Back-up Alarm	●
Brake Control (auto / manual)	●
Hydraglide [™] System	●
Hydraloc [™] System	●
Hydrostatic Drive – Pilot	●
Lift Arm Support Device	●
Power-A-Tach [®] Attachment Mounting	●
Radio	●
Self-Leveling Lift Action	●
Two-Speed Drive	●

- STANDARD
 ○ OPTIONAL

SAFETY IS NO ACCIDENT
 Mustang reminds users to read and understand the operator's manual before operating any piece of equipment. Additionally, make sure all safety devices and shields are in place and functioning properly.

FSC

For more information on Mustang equipment, call our literature hotline

800-628-0491

or visit our website:

mustangmfg.com



West Bend, WI USA • Tel: 262-334-9461 • Fax: 262-338-7517