

 Kawasaki

95ZV-2

ENGINE POWER **263kW**(353hp) OPERATING WEIGHT **33ton** BUCKET CAPACITY **4.3-5.4m³**

W H E E L L O A D E R



Performance that ne

Wheel loaders that deliver premium power...



Backed by more than 45 years of innovative experience...

Durability and reliability you can count on...

er quits...



As the oldest on-going manufacturer of rubber tire wheel loaders in the world, Kawasaki specializes in the design and manufacture of articulated wheel loaders.

You get a machine with a 45-year heritage of successful innovations.

The power and productivity that a Kawasaki wheel loader brings to the job is a result of that experience.

Kawasaki loaders are designed with durability to provide years of reliable service.

Backed by a dealer network of heavy equipment experts and dedicated support staff in the Kawasaki parts and service organization, your investment in a Kawasaki loader is an excellent choice that will pay dividends for years to come.



POWER AND PERFORMANCE PROVIDE UNMATCHED PRODUCTIVITY



COMPUTER CONTROLLED ENGINE

The Engine Control Module (ECM) allows the engine performance to be modified to fit the application requirements. It also provides a wide range of operating data and fault codes to assist in diagnostic and troubleshooting. Cummins provides diagnostic tools to allow technicians to quickly recover engine information for fast, accurate analysis.

Euro Stage IIIA and EPA Tier III emission standards are met by using proven technologies that keep the overall design simple and less costly to maintain.



Use Kawasaki recommended fuel to prevent engine from damage. Consult your local Kawasaki dealer about Kawasaki recommended fuel.

IMPROVED PERFORMANCE OF RIMPULL FORCE AND ACCELERATION

The powertrain has been designed for more efficient operation in a wide variety of applications. Improved torque characteristics and efficient match between the engine and torque converter provide outstanding performance.

POWER/FUEL EFFICIENT MODE SELECTION ⁰¹

The engine mode switch allows the operator to select either the power mode for maximum power in extreme applications or the fuel efficient mode, for most applications, which provides better fuel economy.

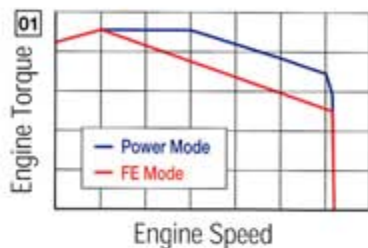

ADVANCED HYDRAULIC COOLING FAN CONTROL FEATURES ⁰²

The hydraulically driven cooling fan's speed is controlled by the cooling system temperatures which reduces fan noise and improves fuel efficiency.

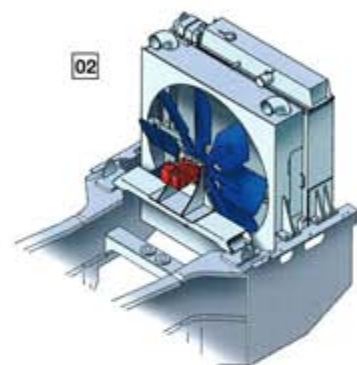

TPD ⁰⁴

Standard Torque Proportioning Differentials (TPD) improve traction in slippery conditions.

Z-LINK AND CENTER PIN ARTICULATION

As a pioneer of Z-linkage, Kawasaki loaders provide outstanding breakout force from a simple, reliable linkage. Kawasaki center pin design is rugged and durable, providing thousands of hours of trouble free operation.



LOAD SENSING HYDRAULIC SYSTEM FOR STEERING LINE

An energy efficient design of the hydraulic system provides for steering flow to supplement the main circuit once steering demand is met. This allows for full utilization of the pump capacity for efficient operation in all conditions.



IDLE MANAGEMENT SYSTEM

The idle management system allows for lower idle speed when idling for extended periods to conserve fuel. It also increases idle speed and reduces fan speed when the engine is cold to reduce warm up time, for better productivity.

OUTBOARD WET DISC BRAKE ⁰³

Sealed wet disc brakes provide high capacity braking and protection from contamination. The dual brake system separates the front and rear axles for added safety.

LSD (OPT) ⁰⁵

For applications with extreme traction requirements, the Limited Slip Differential (LSD) provides additional traction capability.

LOCK UP TORQUE CONVERTER (OPT)

An optional lock-up clutch in the torque converter provides direct drive efficiency in the top speed ranges. This significantly improves fuel economy in long haul, load and carry applications and improves performance in hill climbing applications.

ACTIVE TRACTION CONTROL (OPT)

Traction Control reduces wheel slippage by automatically dropping engine speed when conditions indicate wheel spin.

ELS (Efficient Loading System) ⁰⁶

Increases rimpull power and slows bucket movement when digging while demanding less fuel.

Increases productivity and fuel efficiency.

Switch on instrument control panel allows operator to activate from cab.

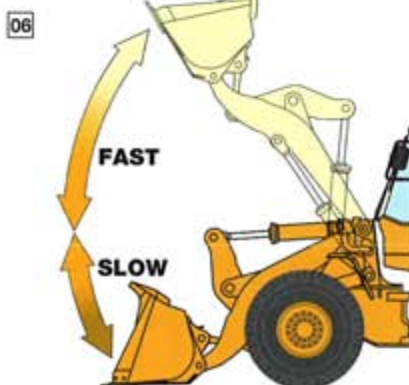

DURABLE AND DEPENDABLE

LIFT ARMS/BUCKETS ⁰¹

With the strongest lift arms and linkage in the industry, Kawasaki loaders perform well in a wide variety of applications.

High breakout force and excellent bucket rollback mean bigger loads and better load retention.

Buckets are designed for easy loading and are equipped with bolt-on cutting edges for easy changing.

The bucket leveler and boom kickout are standard.



SEALED BUCKET HINGE PINS ⁰²

The special seal in the bucket hinge pin provides excellent sealing and grease retention which extends pin life.



INCREASED GREASING INTERVALS FOR UNIVERSAL JOINTS ⁰³

Sealed universal joints only require greasing every 12000 hours. This reduces maintenance costs significantly and provides greater durability.



WET DISC PARKING BRAKE

The high capacity, wet disc parking brake supplies ample braking force to meet all brake capacity regulations.

FULL BOX FRAME CHASSIS ⁰⁴

Full box section frame is the strongest in the industry and resists twisting loads better than plate frames.

KAWASAKI MADE HYDRAULIC VALVES

As a leading manufacturer of precision hydraulic components, Kawasaki offers high quality control valves for precise operation.

Pilot assisted controls offer fingertip operation.

RIDE CONTROL FEATURE (OPT) ⁰⁵

Ride control offers a smooth ride to improve load retention and increase travel speeds.

BUFFER RINGS IN HYDRAULIC CYLINDERS

The hydraulic cylinders utilize a buffer ring to improve sealing capability to reduce leakage.

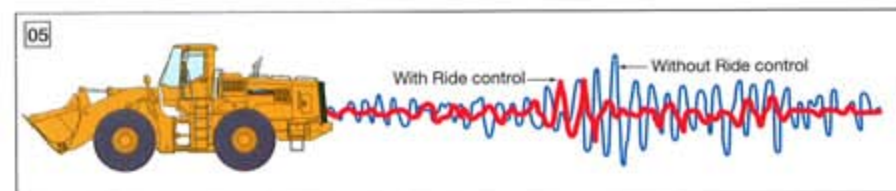

EASY ACCESS SIMPLIFIES SERVICING



EASY ACCESS SIMPLIFIES SERVICING

Maintenance is enhanced with the engine access panels that can be opened wide for better access.

Filters are conveniently located for easy change and the grease fittings are grouped to reduce maintenance time and insure proper lubrication.



HALOGEN HEAD LAMPS ⁰⁶

Front and rear working lights are bright, halogen lamps for improved safety and visibility.

LED REAR LAMPS (OPT) ⁰⁷

Long life, LED lamps are available as an option for the rear tail lights.

These lights are very bright and durable.



DT CONNECTORS ⁰⁸

Sealed Deutsch DT electrical connectors are used throughout the system to reduce corrosion and provide a positive connection.

HIGH QUALITY FINISH PAINT FOR SHEET METAL PARTS ⁰⁹

Kawasaki's sophisticated painting process utilizes ED (Electro-deposition) primer, a baked Melamine Alkyd finish coat as well as a fluoroc super protection coat for a durable and attractive finish.

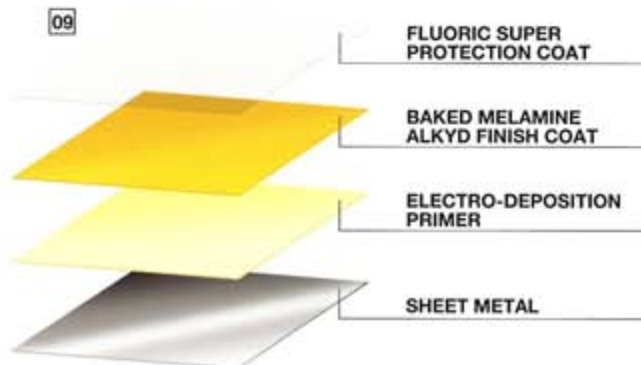

C THE COMFORT ZONE



CAB

Excellent visibility in all directions is enhanced with both inside and outside mirrors.

The front windshield is flat glass mounted in rubber gaskets that make windshield replacement fast and easy.

Viscous mounting of the cab reduces vibration and noise.

ROPS AND FOPS CAPABILITY 01

The operator's cab is fully certified to meet all ROPS (Rollover Protective Structure) and FOPS (Falling Object Protective Structure) regulations.



FULLY AUTOMATIC HEATER AND AIR CONDITIONER 02

The thermostatically controlled air conditioner/heater provides automatic adjustment to keep the operator comfortable in any environment. The high capacity vents provide adequate airflow for efficient defrosting and an even temperature distribution. By pressurizing the cab, the climate control system keeps dust out of the cab.



MULTI ADJUSTABLE FUNCTION OPERATOR'S SEAT 03

The fully adjustable suspension seat offers excellent comfort to reduce operator fatigue and increase productivity.

The optional air suspension seat provides higher capacity and overall comfort and reliability.





SINGLE SHIFT CHANGE LEVER

Single, twist grip transmission shift lever is conveniently mounted on the steering column.

MODM ⁰⁴

The MODM, Machine Operation Diagnostic Module, offers information to make the operation, maintenance and troubleshooting more efficient. With this information operators, maintenance and technical personnel can quickly determine key operating data.



RADIO (OPT) AND UTILITY BOXES

Operators appreciate the convenience of the radio, glove box, cup holder and climate controlled storage box.

ADDITIONAL DIRECTIONAL SWITCH (OPT) ⁰⁵

The directional switch located near the hydraulic control levers allows the operator to easily make directional shifts without removing his left hand from the steering wheel.



DOWNSHIFT BUTTON ⁰⁵

The downshift button located on the boom control lever provides for quick, convenient downshifting from 2nd gear to 1st gear.

TILT AND TELESCOPIC STEERING

The tilt and telescopic steering column adjusts to fit a variety of operator needs and offers greater comfort and efficiency.

ADJUSTABLE DECLUTCH PRESET SWITCH ⁰⁶

The adjustable declutch system allows the operator to select the location of the left brake pedal where the declutch engages. This allows the operator to adjust for varying operating conditions easily.



IMPROVED KICKOUT FEATURE ⁰⁶

Dual boom kickout can be set by the operator from inside the cab.

A high kickout can be set for loading trucks or hoppers while a low kickout can be set to return the boom to the proper height for digging.

SHIFT HOLD SWITCH (OPT)

The shift hold switch allows the operator to hold the transmission in the current range with a convenient button located on the hydraulic control lever when the transmission is in the automatic mode.

K-LEVER (OPT) ⁰⁷

K-LEVER joystick steering reduces operator fatigue and increases productivity.

Transmission speed selection is done with buttons on the K-Lever and direction changes are handled with the convenient trigger switch.



95ZV-2 OPERATING SPECIFICATIONS

Engine

Make & model	CUMMINS "QSX15" diesel engine
Type	4-cycle, water-cooled, direct injection, with turbocharged and air cooled intercooler
Rated power	Gross 291 kW(390 hp)/2,000 rpm Net 263 kW(353 hp)/2,000 rpm
Maximum torque	Gross 1,825 N·m(186.2 kgf·m)/1,400 rpm
Number of cylinders (bore X stroke)	6 137 mm X 169 mm
Total displacement	15.03 lit
Cooling type	Hydraulic drive pusher type fan Pressurized radiator
Fuel injection pump	Cummins high pressure injection
Governor	All-speed electrical type
Air cleaer	Dry type(Double element)
Generator	AC 24V 1.8 kW(75 ampere)
Starter motor	DC 24V 8.3 kW(11.1 hp)
Batteries	DC 12V 140 Ah X 2

Transmission & Torque converter

Transmission make & type	Kawasaki, Full power shift		
Torque converter make & type	Kawasaki 3-element, one-stage, one-phase		
Traveling speed		Forward	Reverse
	1st	7.7 km/h	8.3 km/h
	2nd	14.5 km/h	15.6 km/h
	3rd	24.4 km/h	26.1 km/h
	4th	34.8 km/h	-
Note	With 29.5(L3)		

Axles & Final Drives

Type	4-wheel drive
Axle make & type	Kawasaki Full-floating type
Differential gear	Spiral bevel gear, torque proportioning, single stage reduction
Final reduction gear	Outboard mounted, Internal planetary gear
Rear axle oscillation angle	±12°
Tire(standard)	29.5(L3) Tubeless

Weight change

Option item	Operating weight(kg)	Tipping load(kg)			Overall width(mm) (outside tire)	Overall height(mm)	Overall length(mm)	
		Straight	at 37°	Full turn				
Tires	26.5R25(L3)	-680	-520	-470	-460	-90	-50	+40
	26.5R25(L4)	-280	-210	-190	-190	-60	-20	+20
	26.5R25(L5)	+60	+40	+40	+40	-60	-10	+10
	29.5R25(L3)	±0	±0	±0	±0	±0	±0	±0
	29.5R25(L4)	+500	+380	+340	+340	+10	+35	-30
	29.5R25(L5)	+840	+640	+580	+560	+10	+40	-40
	26.5-25-24PR(L3)	-420	-320	-280	-280	-90	-50	+40
	26.5-25-24PR(L4)	-20	-20	-10	-10	-60	-20	+20
	26.5-25-24PR(L5)	+570	+430	+380	+380	-60	-10	+10
	29.5-25-24PR(L3)	±0	±0	±0	±0	±0	±0	±0
	29.5-25-24PR(L4)	+730	+550	+490	+490	+10	+35	-30
29.5-25-24PR(L5)	+1080	+820	+730	+720	+10	+40	-40	
Counter weight	+410	+1020	+880	+850	-	-	-	
Belly guard	+230	+390	+350	+340	-	-	-	
CE package	+190	+220	+190	+180	-	-	-	

Brake system

Service brake	4-wheel wet-disc Controlled by fully hydraulic system Dual circuits
Parking brake	Spring applied oil pressure released type located on front driveline

Steering system

Type	Articulated frame steering, hydraulic power steering unit, pilot operated type
Steering valve	Kawasaki, Orbitrol and spool type
Full articulation angle	40° to each side

Loading system

Type	Front end loading, Z bar linkage system	
Hydraulic cycle time	Lifting(at full load)	6.1 sec
	Lowering(empty)	4.0 sec
	Dumping	1.5 sec
	Total cycle time	11.6 sec





Hydraulic system

Oil pump	Steering oil pump	Gear type, 358 lit/min 6.9 MPa(70 kg/cm ²) @ 2,000 rpm
	Main oil pump	Gear type, 190 lit/min, 6.9 MPa(70 kg/cm ²) @ 2,100 rpm
	Pilot oil pump	Gear type, 169 lit/min, 6.9 MPa(70 kg/cm ²) @ 2,100 rpm
Lift cylinder	type	Double acting piston
	number,bore x stroke	2 X 190 mm bore X 953 mm stroke
Tilt cylinder	type	Double acting piston
	number,bore x stroke	2 X 160 mm bore X 605 mm stroke
Steering cylinder	type	Double acting piston
	number,bore x stroke	2 X 90 mm bore X 600 mm stroke
Relief set pressure	Control valve	20.6 MPa(210 kg/cm ²)
	Steering valve	20.6 MPa(210 kg/cm ²)

Service refill

Fuel tank	465 lit
Engine lubricant(including oil pan)	50 lit
Engine cooling water	100 lit
T/M & T/C	65 lit
Axle front/rear	200 lit
Hydraulic oil tank	150 lit
Hydraulic system(including oil tank)	265 lit

Bucket

			Standard boom				
			General purpose(stock pile)		Rock straight	Rock V-edge	Coal
			Bolt-on edges	Teeth	Teeth	Teeth	Bolt-on edges
			GSC	GST	RST	RVT	
							
Bucket capacity	heaped	m ³	5.0	4.8	4.3	4.5	7.5
	struck	m ³	4.3	4.1	3.7	3.8	6.4
Max. dumping clearance		mm	3,220	3,105	3,100	2,970	3,130
Max. dumping reach		mm	1,350	1,420	1,425	1,550	1,425
Max. hinge pin height		mm	4,490				
Digging depth (with bucket level)		mm	130	160	160	160	130
Breakout force		kN	245	265	265	226	225
Bucket tilt-back angle	at carry position	deg	51°				
Overall length		mm	9,280	9,420	9,420	9,600	9,410
Overall height	up to cab top	mm	3,760				
	bucket full raise	mm	6,130	6,130	6,190	6,190	6,415
Overall width	outside tire	mm	3,220				
	outside bucket	mm	3,450	3,465	3,465	3,465	4,080
Tread		mm	2,440				
Wheel base		mm	3,600				
Min. turning radius (bucket carry position)	at outside bucket	mm	7,335	7,380	7,380	7,380	7,660
	at center of outside tire	mm	6,160				
Min. ground clearance		mm	500				
Full articulation angle		deg	40°				
Operating weight	with ROPS CAB	kg	30,480	30,310	30,770	30,900	31,060
Static tipping load	straight	kg	23,560	23,730	23,280	22,940	22,340
	at 37°	kg	19,490	19,620	19,255	18,970	18,480
	full turn	kg	19,130	19,260	18,900	18,620	18,140

The weight and load figure includes 29.5(L3) tubeless tire, ROPS cab, lubricant, coolant, full fuel tank and operator.

Bucket selection charts

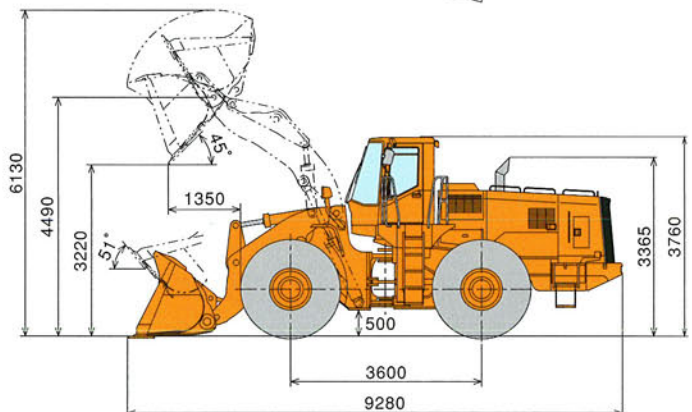
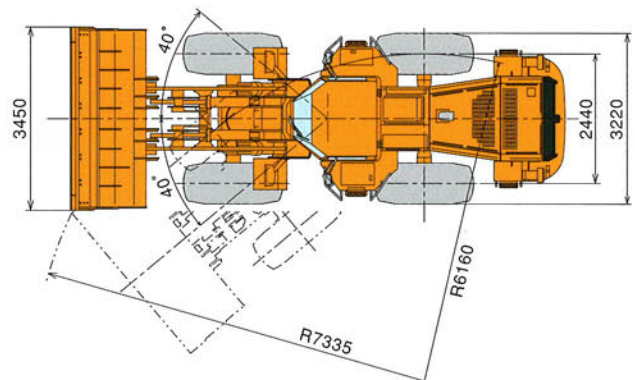
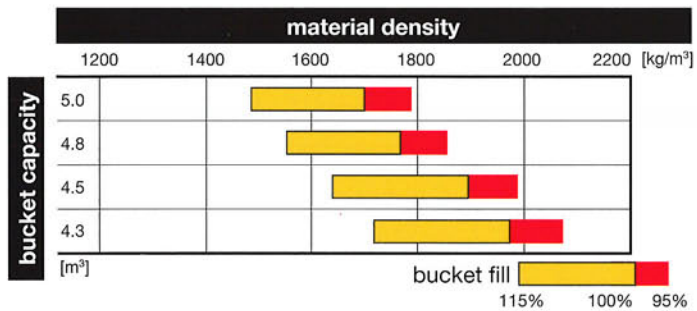

Equipped with GSC bucket, 29.5 (L3) tubeless tire and ROPS cab.