

MANISCOPIC

MLT 742
Turbo

- Maximum lifting height : 6.90 m
- Capacity : 4200 kg
- Maximum forward reach : 3.93 m
- Torque convertor





MLT 742 TURBO - PFB 45 MT 1670

 **MANITOU**

MLT 742 Turbo

 **Lifting capacity**4200 kg
(load centre at 500mm from forks heels)
Tipping load at maximum reach1990 kg

 **Lifting height :**6.90 m
Times : unladen/loaded (in s)
Lifting7/7.5
Lowering5.3/5.2
Boom extension.....8.2/9.0
Boom retraction.....6.2/6.0
Time unladen (in s)
Crowd3.5
Dump3.0

 **Tyres**
14.9 - 24 T 35 18 PR

 **Forks (mm)**
Length.....1200
Width X thickness.....125 x 45
Maximum distance between forks.....1260
Carriage rotation.....146°

 **Oil bath multidisc brakes on front and rear axles**

 **Perkins engine**
Turbo 120 : 1104 C - 44 TA4 cyl. - 4400 cm³
Power (ISO/TR 14396)101 HP/74,5 kw
Maximum torque
(ISO/TR 14396) :412 Nm at 1400 rpm
Direct injection
Water cooling

 **Transmission**torque convertor
Number of speeds4/4
Reversing shift.....electrohydraulic
Limited slip differential lock on the front axle
Maximum speed.....25 km/h

 **Hydraulic**
Turbo :105 l./mn - 270 bars
Gear pump
3 levers
Flow divider with priority to braking and steering

 **Capacities**
Hydraulic oil125 l
Fuel tank120 l

 **Weight unladen (with forks)**7585 kg
Overall height2.30 m
Overall width2.26 m
Overall length (at forks carriage)4.80 m
Ground clearance0.45 m
Turning radius (outside wheels)3.81 m
Drawbar pull9300 daN

Forward reach at maximum height : 1,03 m

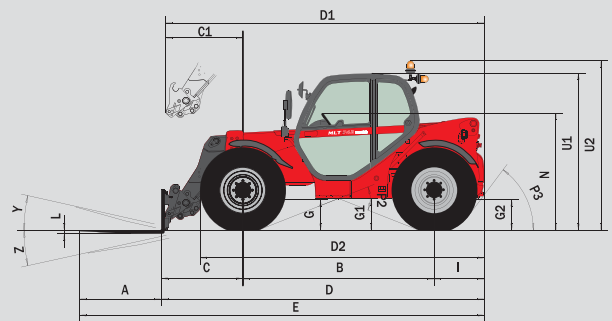
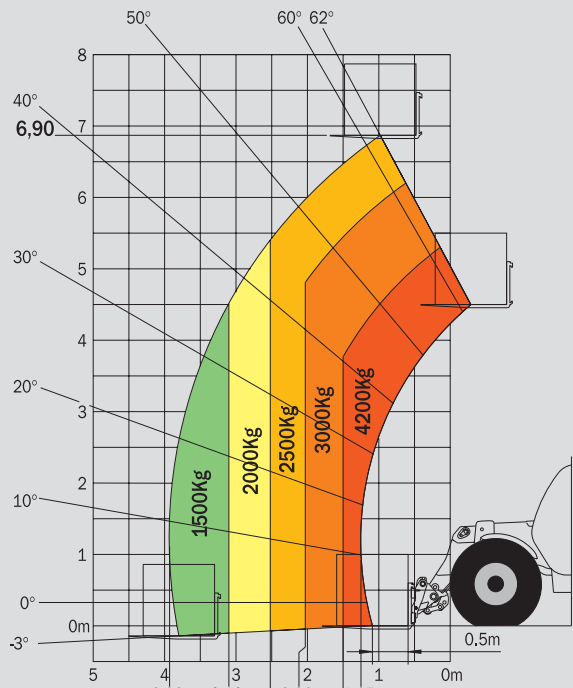

| MLT 742 T | |
|-----------|--------|
| A | 1200 |
| B | 2810 |
| C | 1232 |
| D | 1288 |
| C1 | 4805 |
| D1 | 4861 |
| D2 | 4158 |
| E | 6005 |
| F | 1846 |
| F1 | 1846 |
| G | 455 |
| G1 | 440 |
| G2 | 440 |
| I | 763 |
| J | 865 |
| K | 1260 |
| L | 50 |
| N | 1690 |
| O | 125 |
| P2 | 38° |
| P3 | 53° |
| R | 3610 |
| S | 7654 |
| T | 3505 |
| U1 | 2300 |
| U2 | 2550 |
| V | 4865 |
| V1 | 1360 |
| V2 | 3818 |
| W | 2261 |
| Y | 12,3° |
| Z | 133,5° |

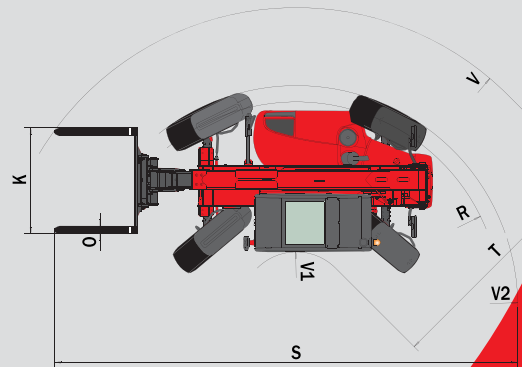
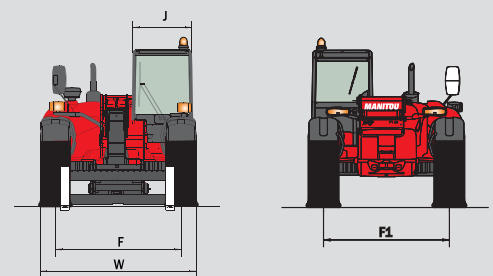

This publication in no way constitutes an offer and the company reserves the right to alter specification without prior notice.
The MANITOU models presented in this brochure can be supplied complete with optional equipment attachments.

