

# MANIACCESS

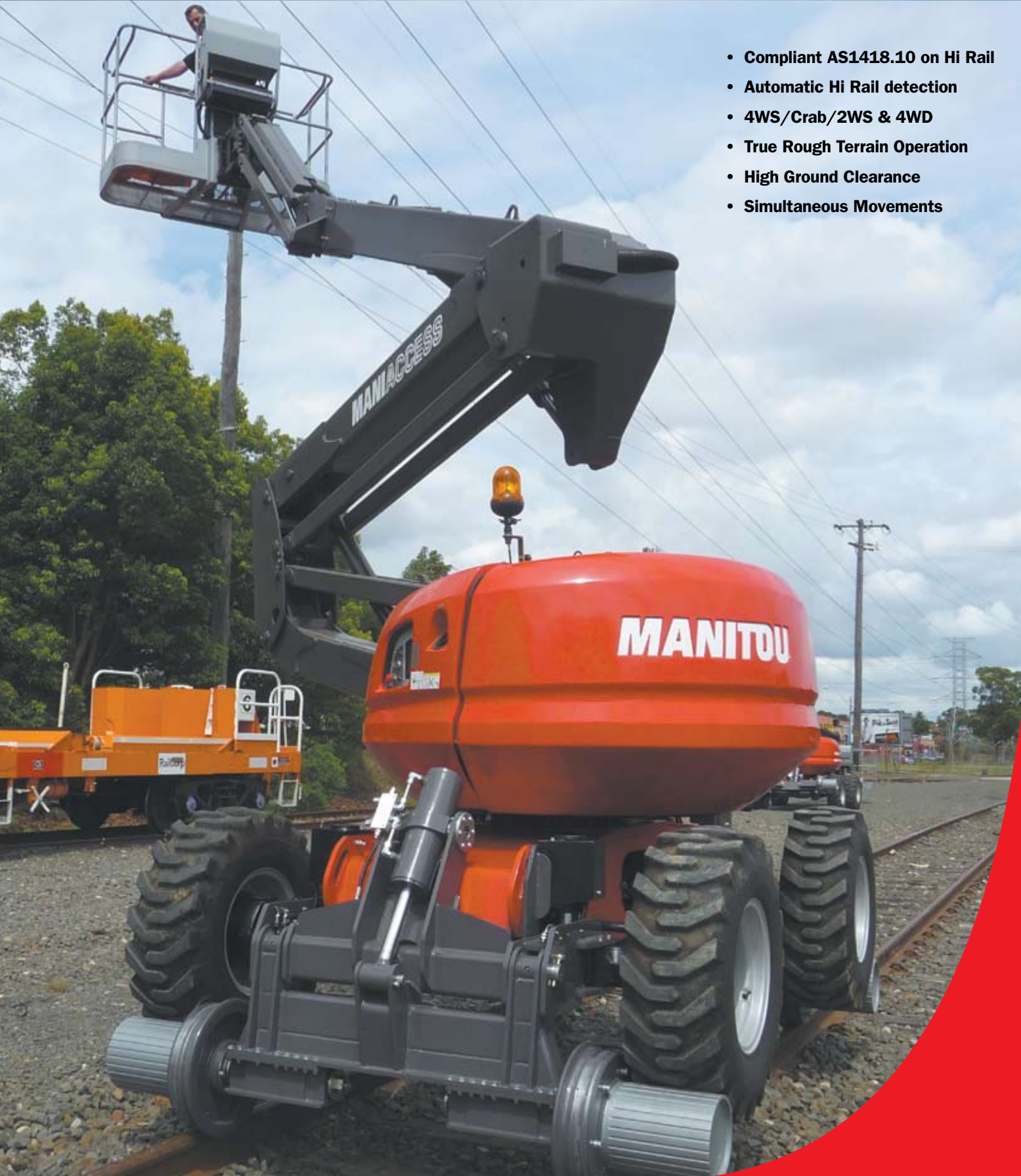









**MANIRAIL**  
**160 ATJ**

- Compliant AS1418.10 on Hi Rail
- Automatic Hi Rail detection
- 4WS/Crab/2WS & 4WD
- True Rough Terrain Operation
- High Ground Clearance
- Simultaneous Movements



# Manitou, the standard of quality, the standard of Australia

## 160 ATJ

-  **S.W.L.**..... 230 kg including 2 people  
**External use** : ..... wind 45 km/h
-  **Working height** ..... 16.25 m  
**Platform floor height** ..... 14.25 m
-  **Max. outreach** ..... 9.10 m  
**Up and over clearance**..... 7.15 m  
**Overall length** ..... 7 m  
**Length** (transport position)..... 5 m  
**Overall width**..... 2.30 m  
**Overall height** ..... 2.37 m  
**Basket size** ..... 1.80 m x 0.80 m  
**Ground clearance** ..... 42.5 cm  
**Turning radius ins/outside**..... 1.32/3.66 m
-  **Turret rotation** ..... 350°  
**Basket rotation** ..... 180°  
**Jib movement**..... 140°
-  **Engine** (Low emission)  
PERKINS 404C22 ..... 45 HP
-  **Maxi. travel speed** ..... 5.8 km/h
-  **Gradeability on rough terrain** ..... 40 %  
**Max. slope accepted** ..... 5° or 9%
-  **Hydraulic tank**..... 54 l.  
**Diesel tank** ..... 52 l.
-  **Tyres** ..... 18  
4 wheel drive/4 wheel steer/crab steer
-  **Weight** ..... 9150 kg

### Standard equipment

- Proportional controls
- 4 simultaneous movements
- Foam filled tyres
- Differential lock
- Limited front axle slip
- Diagnostic tools
- Hour meter
- Horn
- Rotating beacon
- Slope and overload alarm in the basket
- Overslope unlocking
- Lifting brackets
- Safety electric pump
- 230 V auxiliary power cable

### Options

- **Oscillating axle**
- **Continuous rotation**
- **On board generator set**
- Electric plug in platform (230V)
- Air predisposal in the platform
- Water predisposal in the platform
- Working lights
- Customised Painting
- Cold conditions -25°C
- Biodegradable oil
- All motion alarm
- Drive alarm
- Safety harness

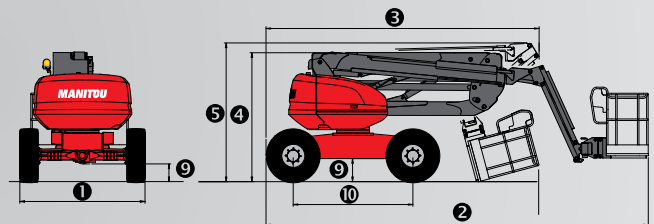
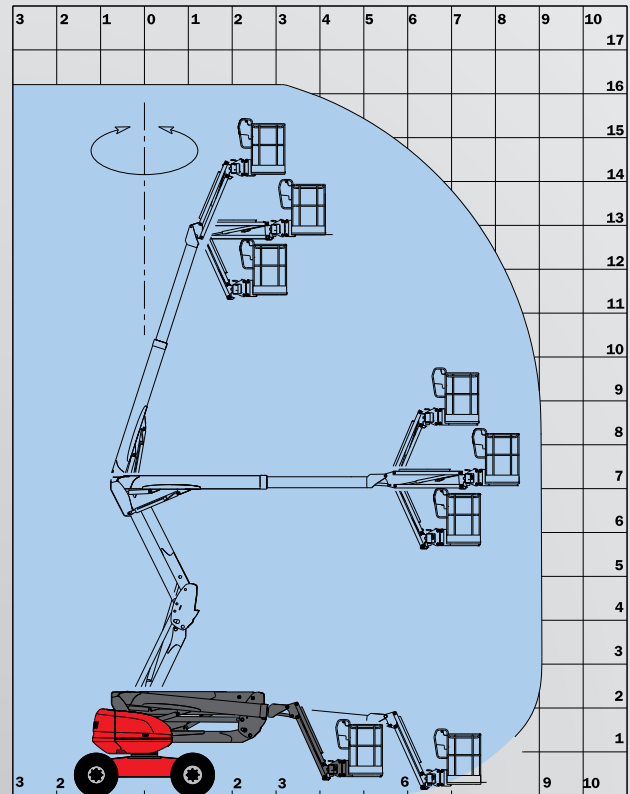

A	7025
A1	5020
B	2200
C	2370
C1	2530
D	2300
E	425
F	325
G	1325
G1	3201
G2	4120
G3	8540
G4	7665
H	3665
H1	14250
H2	12790
H3	7150
H4	305
I	3820
J	6215
K	2730

mm

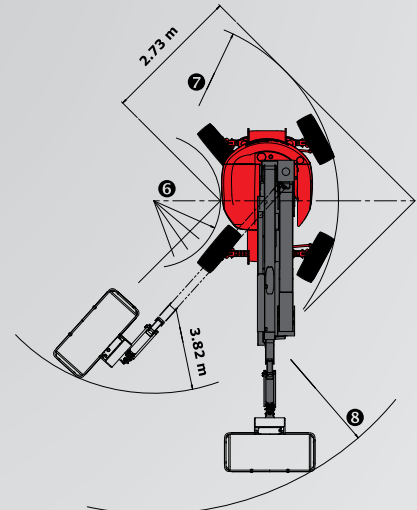

This publication in no way constitutes an offer and the company reserves the right to alter specification without prior notice.  
The MANITOU models presented in this brochure can be supplied complete with optional equipment attachments.

For more information on the Maniaccess range  
please contact MANITOU Australia on:  
Email: [info.mau@manitou.com](mailto:info.mau@manitou.com) or phone 02 9517 3174.

