

# BOMAG

## SINGLE DRUM VIBRATORY ROLLERS BW 226 DH-4, BW 226 PDH-4

### PERFORMANCE DATA

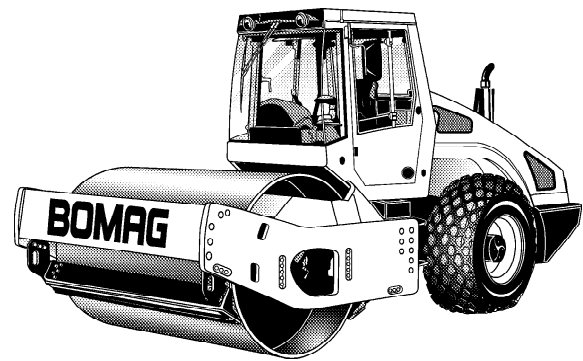

Machine type	Compaction output (m <sup>3</sup> /h)			
	Rock fill	Gravel, sand	mixed soil	Silt, clay
BW 226 DH-4	1180-2120	880-1750	680-1200	350-700
BW 226 PDH-4	1180-2120	880-1750	680-1200	385-770

Machine type	Compacted layer thickness (m)			
	Rock fill	Gravel, sand	mixed soil	Silt, clay
BW 226 DH-4	2,00	1,50	1,00	0,50
BW 226 PDH-4	2,00	1,50	1,00	0,55

# BOMAG

# Technical Data

## Shipping dimensions in m<sup>3</sup>

	without ROPS	with ROPS
BW 226 DH-4	36,938	49,337
BW 226 PDH-4	36,938	49,337

## Standard Equipment

- Warning, information and operation displays with LCD
- Hydrostatic travel and vibration drive
- Anti Slip Control (ASC)
- Hydrostatic articulated steering
- Articulated joint lock
- Rear axle with twin spring accumulator brakes
- No-Spin differential lock
- Warning horn
- Single lever control for travel and vibration
- Swivel seat, adjustable in height and longit. direction, with two armrests
- Contact scrapers (DH:Plastic)
- Scrapers (PDH:Steel)
- Emergency STOP
- Noise insulation
- Back-up warning system
- BOMAG ECOMODE
- Engine-TIER III

## Optional Equipment

- \* ROPS cabin with seat belts
  - \* Working lights front/rear
  - ROPS with safety belt
  - Rotary beacon
  - Indicator and hazard lights
  - Padfoot segment kit
  - Contact scrapers (DH:Steel)
  - BOMAG Evib-Meter (BEM)
  - TERRAMETER BTM plus
  - TERRAMETER BTM prof
  - BEM/BCM 05
  - TERRAMETER/BCM 05
  - Special painting
  - Environmentally compliant hydraulic oil
  - Air condition
  - Sun roof
  - Slideable seat
  - Warning, information and operation displays
  - Radio
  - Protective ventilation system
- \* Standard delivery with CE conformity (valid within European Union)

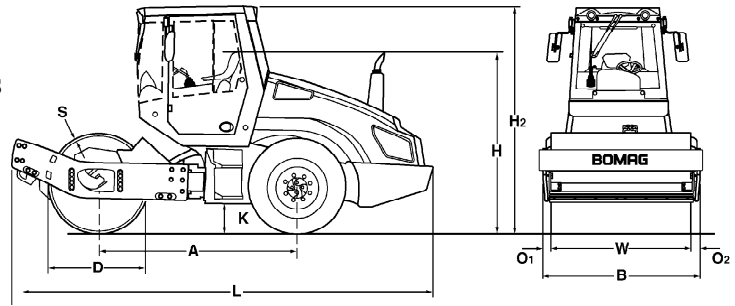

## Dimensions in mm

	A	B	D	H	H2	K	L	O1	O2	S	W
BW 226 DH-4	3355	2440	1700	2300	3072	430	6582	155	155	40	2130
BW 226 PDH-4	3355	2440	1500	2300	3072	430	6582	155	155	35	2130

## Technical Data

### Weights

	BOMAG BW 226 DH-4	BOMAG BW 226 PDH-4
Grossweight	27.000 kg	25.080 kg
Operating weight CECE w. ROPS-cabin	25.210 kg	24.650 kg
Axle load, drum CECE	17.040 kg	16.640 kg
Axle load, wheels CECE	8.170 kg	8.010 kg
Static linear load CECE	80 kg/cm	80 kg/cm

### Dimensions

	BOMAG BW 226 DH-4	BOMAG BW 226 PDH-4
Working width	2.130 mm	2.130 mm
Width (wheels)	2.370 mm	2.370 mm
Track radius, inner	3.950 mm	3.950 mm

### Driving Characteristics

	BOMAG BW 226 DH-4	BOMAG BW 226 PDH-4
Speed (1)	0- 10,0 km/h	0- 10,0 km/h
Max. gradeability without/with vibr.	48/45 %	50/48 %

### Drive

	BOMAG BW 226 DH-4	BOMAG BW 226 PDH-4
Engine manufacturer	Deutz	Deutz
Type	TCD 2012 L06	TCD 2012 L06
Cooling	water	water
Number of cylinders	6	6
Performance ISO 3046	150 kW	150 kW
Performance SAE J 1995	201 hp	201 hp
Speed	2.200 min-1	2.200 min-1
Fuel	diesel	diesel
Electric equipment	12 V	12 V
Drive system	hydrost. standard	hydrost. standard
Drum driven	standard	standard

### Drums and Tyres

	BOMAG BW 226 DH-4	BOMAG BW 226 PDH-4
Number of pad feet		150
Area of one pad foot		137 cm <sup>2</sup>
Height of pad feet		100 mm
Tyre size	23.5-25/16PR	750/65-26DT820

### Brakes

	BOMAG BW 226 DH-4	BOMAG BW 226 PDH-4
Service brake	hydrost.	hydrost.
Parking brake	hydromec.	hydromec.

### Steering

	BOMAG BW 226 DH-4	BOMAG BW 226 PDH-4
Steering system	oscil.artic.	oscil.artic.
Steering method	hydrost.	hydrost.
Steering / oscillating angle +/-	35/12 grad	35/12 grad

### Exciter system

	BOMAG BW 226 DH-4	BOMAG BW 226 PDH-4
Drive system	hydrost.	hydrost.
Frequency	26/26 Hz	26/26 Hz
Amplitude	1,90/1,00 mm	2,00/1,05 mm
Centrifugal force	330/173 kN	330/173 kN
Centrifugal force	33,7/17,6 t	33,7/17,6 t

### Capacities

	BOMAG BW 226 DH-4	BOMAG BW 226 PDH-4
Fuel	340 l	340 l

Technical modifications reserved. Machines may be shown with options.

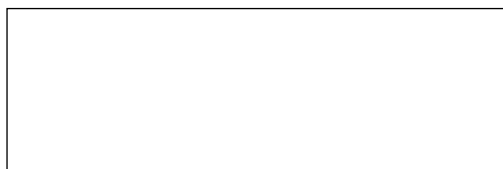

**BOMAG**  
 Hellerwald  
 D-56154 Boppard  
 P.O. Box 5162  
 Tel. (0)6742 - 1000  
 Fax (0)6742 - 3090  
 Fax (0)6742 - 3090

# BOMAG