

MITSUBISHI MOTOR GRADERS MG460/MG560

Australian Version



The Next
Advancement
in Value

MG460

Weight 17,700 kg
Net Power
Gear 1-3 116 kW (155 HP)
Gear 4-8 (Forward) 138 kW (185 HP)
Gear 1-8 (Reverse) ... 116 kW (155 HP)
Blade Width 3,710 mm

MG560

Weight 18,680 kg
Net Power
Gear 1-3 139 kW (186 HP)
Gear 4-8 (Forward) 157 kW (210 HP)
Gear 1-8 (Reverse) ... 139 kW (186 HP)
Blade Width 4,010 mm

Mitsubishi 60 Series ——— Your Next



Power-Performance

— Engine

The new 60 series motor graders are fitted with Mitsubishi's well proven high capacity 6D24 engine and now feature variable horsepower (VHP) which provides an overall 11% increase in machine performance. The Mitsubishi 6D24-TUN (MG460) and 6D24-TUM (MG560) engines offer excellent fuel efficiency and high torque for powerful lugging performance.

— Transmission

Fitted with the industry's only "Eight (8) Speed F/R Direct Drive Planetary Transmission", the 60 series provides gear ratios to suit all grading applications

from heavy ripping to light maintenance. The 60 series transmission is manufactured by Mitsubishi to perfectly match engine performance.

— Frame

Mitsubishi's unique front frame and rear section is specifically designed to provide high strength and durability. The front frame section modulus is the highest in the industry incorporating 50 mm side frame sections. Front and rear axle weight distribution is ideal providing exceptional blade (moldboard) down pressure.

High-Value Grader



Operator Comfort and Visibility

- Operator comfort is at a premium with the 60 series cabin. The spacious ROPS/FOPS cabin incorporates automotive styling and features aimed to maximize the operator's productivity.
- Industry standard levers, gauges and switches are ergonomically located to enhance machine operation. The suspension seat is fully adjustable to accommodate any operator regardless of posture or weight.
- Noise levels are below industry standards due to the acoustic design of the cabin. All round work site vision from the operator platform is unrestricted with blade (moldboard) and rear implement (ripper/scarifier, option) vision being exceptional due to the large one piece front and rear windcreens. All windows are tinted as standard.

Durability

- For improved durability of implements, the 60 series adopts hardened circle teeth, circle shoe guides with bronzed wear strips, heat-treated blade rails and bronzed rail guides, as well as fully covered circle drawbar.

Hydraulic System

- The 60 series hydraulic system adopts a large-capacity variable displacement pump with a close-center load sensing system. The hydraulic system provides high implement speed with multi function.
- A large-capacity return-line filter and magnetic suction strainer ensure the hydraulic oil cleanliness is at a premium.
- The hydraulic system incorporates lock valves on the blade lift, blade tilt, wheel lean and rear ripper/scarifier as an option.

Maintenance and Serviceability

- The unique design of the 60 series graders is aimed at reducing maintenance and servicing costs. The large upward opening engine bay side doors provide unlimited access for ease of servicing, sight glasses are provided for routine fluid checks and a gear driven engine fan eliminates the need for fan belt replacement or adjustment.
- For safety, all daily checks including fueling are performed from ground level.
- A built in air supply is provided as standard for tire inflation.

Environmentally Responsible Design

- Engine meets EU emission regulations.
- Low-noise operation ensures the operator and the operational surrounding are taken into consideration.
- No fiber-reinforced plastic is used in the construction of the 60 series motor graders.



Mitsubishi Engines

Direct-injection, turbocharged Mitsubishi 6D24-TUN (MG460) and 6D24-TUM (MG560) engines offer superior output and high torque levels, while exhaust reduction countermeasures ensure environmental friendliness. Combined with the direct power shift (DPS) transmission that was designed especially for the 60 series, these engines offer excellent lugging performance even in the most demanding situations. Mitsubishi engines also feature reduced fuel consumption, easy starting and outstanding durability.

◆ Variable Horsepower

The MG460 and MG560 incorporate Variable Horsepower providing an average 17% increase in engine output in the 4th to 8th gears. VHP provides additional power when roading the machine from job site to job site. VHP is also available when additional power is required for high speed applications (mixing and material spreading etc).

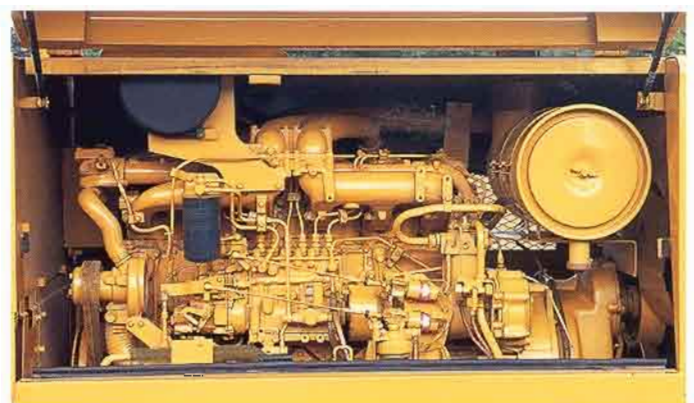

◆ EU Emissions

Mitsubishi's clean-burning engines meet EU emission regulations.

Delivering Power to Order, Yet Easy on the Environment

Direct Power Shift Transmission

The direct drive planetary gear transmission, which was developed especially for the 60 series motor graders, provides eight forward and eight reverse gears, as well as an internal oil cooled multi-disc parking brake. The eight speed, highly reliable and durable planetary geared DPS transmission, perfectly matches the high performance engines used in this series. Drawbar pull is at an optimum and perfectly match the operating requirements.



Differential Lock/Unlock

The differential lock/unlock feature is standard on the 60 series, improving performance during turning or when operating on rough underfoot conditions. The easy-to-operate lock/unlock switch is located on the console box.



Fail-Safe, Independent Dual Braking System

Air-actuated oil-cooled multi-disc brakes with independent dual cross-over type system on all four rear wheels, provide on demand positive braking with only a light touch of the pedal.

Daily Maintenance and Servicing

- Designed for easy operation, the locking engine compartment side door incorporates a one-touch gas damper. In addition to opening easily, the door is large to provide easy access to all engine components and facilitate oil, battery fluid level and other daily checks. Filters are also easy to change.
- The locking fuel cap, located to the side of the engine compartment, allows fueling from ground level.
- The fuse box is positioned to the right of the operator's seat, making fuse replacement easy.
- The service hour meter is situated on the left side of the steering console so it can be checked easily from ground, without entering the cabin.
- An air supply system is provided as standard. This system can be used as an air source to inflate tires by using an optional tire charge hose.



Safety Features

- The engine can only be started when the transmission lever is in the neutral position.
- A warning buzzer sounds to alert the operator if the transmission shift lever is operated while the parking brake remains engaged.
- If air pressure is insufficient to power the service brakes, an alarm buzzer sounds until pressure is recharged.
- In a two-stage control system, first an alarm buzzer sounds to indicate overheating. If this warning is ignored, the engine will eventually shut off.
- An emergency steering system is available as an option.

Comfortably Spacious Cab for High Operating Productivity

Operator Station

The ROPS/FOPS low profile cabin, fitted as standard, has been ergonomically designed to offer total excellence in operator comfort.

The one piece front windscreen provides an unhindered view of the work site area and the moldboard function. Side and rear vision from the operators station is also at an optimum. Pedals, hydraulic function levers, gear change lever, switches and gauges are arranged to ensure minimum operator fatigue and maximum operator comfort and safety.

The ROPS (Roll-over Protection Structure) is designed to meet ISO 3471-1994 standards. The FOPS (Falling Object Protective Structure) is designed to meet ISO 3449-1992 standards.



Hydraulic Operating Levers

The 60 series motor graders are fitted with "Industry Standard" soft touch, short stroke levers which are direct coupled by rod and ball linkage to the hydraulic control valves. The system provides precise implement control with minimum stress to the operator.



- 1 Blade lift (L) 2 Rear ripper (op.) 3 Blade tip 4 Side shift 5 Circle
- 6 Articulate 7 Scarifier (op.) 8 Center shift 9 Leaning 10 Blade lift (R)

Suspension Seat

The suspension seat provided in the 60 series Mitsubishi motor graders is designed to provide optimum support and comfort for the operator.

The seat is fitted with an internal damper which can be adjusted to the operator's weight. The forward-back, up-down stroke, seat cushion and seat back are fully adjustable to suit the operator's physique to ensure comfortable operation over long periods of operation. Other standard features to meet ISO7096 include an adjustable fold up arm rests, and magazine pocket.





Steering

An infinitely adjustable tilting console-type steering column allows the operator to select the steering position to suit nearly any physique.



Low Noise and Reduced Vibration

To minimize the amount of noise and vibration that reaches the operator, the cabin and engine compartment are fully separated. Also, the engine compartment uses double-layer soundproofing on the cabin side, and the cabin is rubber-mounted.

Transmission Shift Lever

The transmission shift lever allows the operator to select the optimal combination of machine speed and drawbar pull from among eight forward and eight reverse speeds, improving operating efficiency in a variety of operations. The transmission lever requires little effort to adjust, ensuring superb operating smoothness.



Monitoring System

An integrated electronic color liquid-crystal display provides information on various parts of the machine. Switches are easily visible and in an easy-to-operate layout. In addition, an electric monitoring system (EMS) is used to simplify checking of machine conditions during operation.

- 1 Turn signal indicator (left)
- 2 Articulation angle indicator
- 3 Hi-beam indicator
- 4 Turn signal indicator (right)
- 5 Tachometer
- 6 Speed meter
- 7 Engine coolant temperature gauge
- 8 Fuel gauge
- 9 Air pressure gauge
- 10 Hazard switch
- 11 Parking brake indicator
- 12 Differential lock/unlock indicator
- 13 OK monitor check switch
- 14 EMS
- 15 Differential lock/unlock switch
- 16 Lamp switch



Interior (Standard)

An AM/FM stereo radio-cassette with four speakers, glove box, internal cab light and internal rear vision mirrors are provided as standard.



Air Conditioner (Standard)

The 60 series motor graders are fitted with a fully integrated, totally climate control, pressurized air-conditioner which incorporates cooling, heating and demisting. Air vents are adjustable to suit the operators requirements. Fresh air is taken through a replaceable filtration system.



*Meeting Your Needs
for Versatility,
Precision and
Reliability*



Wheel Lean

Hydraulic wheel lean allows the operator to change the grading characteristics of the machine by adding additional front end stability for heavy grading application.



Side Shift

Ditching work is made easy by combining the center shift and wheel lean function.





Bank Cutting

The machine can be set in bank cutting mode from the operator's station. The machine can be set to cut 90 degrees left or right.



Oscillation

The front axle has a large angle of oscillation, providing front axle stability in the roughest of ground conditions.



Small Turning Radius

An ultrasmall turning radius enables 60 series graders to operate with ease even on confined sites.
 Minimum turning radius: 6.9 m (MG460/560)

Hydraulic System

Through the combination of a large-capacity variable pump and a closed-center load-sensing system, hydraulic system pressure and flow volume adjusts optimally to different operating loads, minimizing power loss and ensuring energy efficiency.

Hydraulic Pump

The large-capacity variable hydraulic pump, which incorporates load feedback, reduces vibration and pulsing, for superb durability. This pump design offers excellent implement speed, simultaneous circle and blade movement, and fine operations, particularly at lower engine speeds.

Load Sensing

The load sensing system senses the load on implements to maintain a fixed pressure and flow rate. In combination with a large-capacity variable pump, load sensing ensures ideal operating speed and maneuverability.

Features to Ensure Reliability

Fully Covered Drawbar

The A-frame drawbar is fully covered to ensure optimal reliability by protecting the circle from sand, rocks and other debris.



Circle

The circle adopts hardened teeth and six guide shoes. The guide shoes are equipped with replaceable bronzed wear strips as standard equipment. This configuration is highly durable and friction-resistant, and allows precise, rattle-free operations.



Blade

Equipped as standard with a tip cylinder, the blade has excellent rolling performance, which allows a variety of operations, ranging from leveling sand to mixing, dozing and digging everything from aggregate to clay soil, or snow and ice removal.



Blade Slip Clutch (Optional)

If the blade is subjected to a sharp impact, the blade slip clutch releases providing protection against damage to the blade, circle and draw bar etc. Furthermore, as a safety feature, the operator is also protected as the slip clutch releases automatically when a sudden impact occurs.

DIMENSIONS

Unit: mm

Dimensions [I]

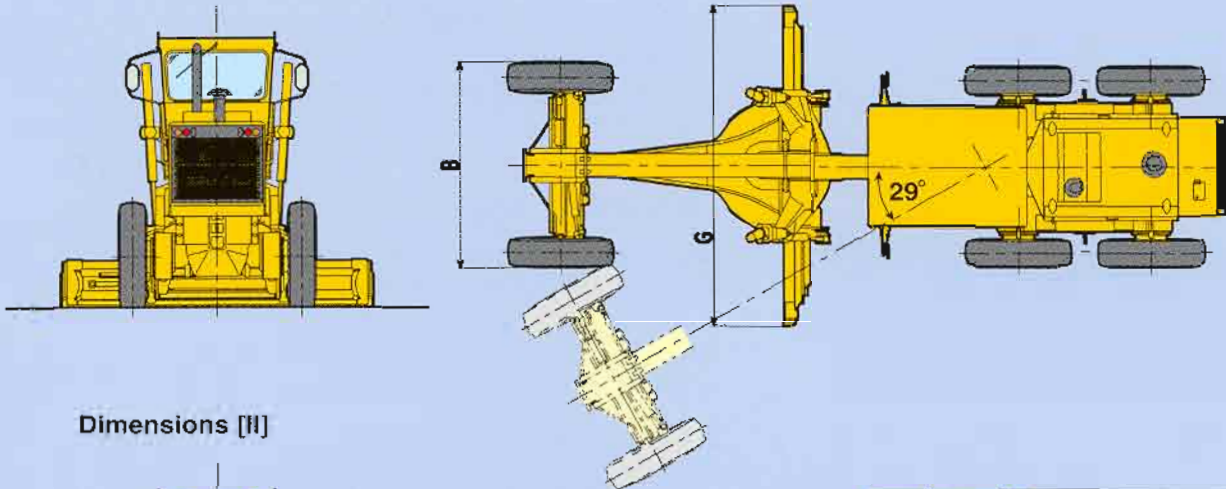

Dimensions [II]

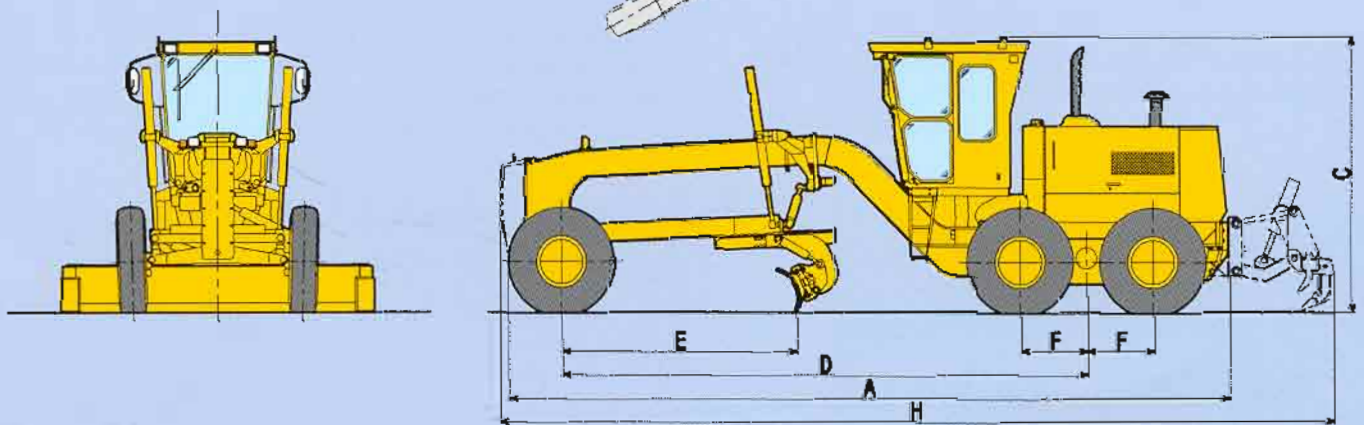

MODEL		MG460	MG560
A: Total Length	mm	8,580	8,610
B: Total Width	mm	2,420	2,440
C: Total Height	mm	3,190	3,215
D: Wheel Base	mm	6,250	6,250
E: Blade Base	mm	2,790	2,780
F: Rear Axle Center	mm	782.5	782.5
G: Blade Length	mm	3,710	4,010
H: Total Length (front counterweight-rear ripper)	mm	9,895	9,895

MODEL		MG460	MG560
Moldboard			
Lift Above Ground	mm	500	525
Drop Below Ground	mm	685	660
Shoulder Reach - Left	mm	1,865	2,085
Shoulder Reach - Right	mm	1,965	2,045
Bank Cutting Angle (both side)	deg.	90	90
Blade Tilt	deg.	46	46
Angle of Cut	deg.	39° to 85°	38° to 84°
Circle Turning Angle	deg.	360	360

ATTACHMENTS

Moldboard		Rear Ripper / Scarifier	Counterweight	Tires & Rims
Front Dozer Blade	Mid-mounted Scarifier			

SPECIFICATIONS

Weight (ISO7134)		MG460		MG560	
MG460 ; 17,700 kg	With 14.00-24-12PR tires (op), rear mounted ripper, front push block, T/M belly guard, operator, Air-Con., ROPS cab, 1/2 tank diesel and lighting/mirrors etc. for road registration.				
MG560 ; 18,680 kg	With 17.5-25-12PR tires (op), rear mounted ripper, front push block, T/M belly guard, operator, Air-Con., ROPS cab, 1/2 tank diesel and lighting/mirrors etc. for road registration.				
Frame		MG460		MG560	
Articulated	deg	29		29	
Minimum Vertical Section modulus	cm ³	2,850		3,650	
Engine		MG460		MG560	
Model-Mitsubishi		6D24-TUN		6D24-TUM	
Number of Cylinders		6		6	
Piston Displacement	ℓ	11.946		11.946	
Net Power					
1st - 3rd Forward & 1st - 8th Reverse	kW	116 (155 HP)		139 (186 HP)	
4th - 8th Forward	kW	138 (185 HP)		157 (210HP)	
Governed Speed	min ⁻¹	2,000		2,000	
Max. Torque	Nm	925@1,200		993@1,200	
Bore × Stroke	mm	130×150		130×150	
Starting Motor	volt	24		24	
Alternator	volt-amp	24-50		24-50	
Transmission		MG460		MG560	
Power-shift (Planetary gear, Hydraulically actuated) with 8 speeds.					
Speeds	1st km/h	3.5/3.3		3.6/3.4	
(Forward/Reverse)	2nd km/h	4.7/4.4		4.9/4.6	
	3rd km/h	7.2/6.7		7.5/7.0	
	4th km/h	9.9/9.2		10.3/9.6	
	5th km/h	14.1/13.2		14.7/13.8	
	6th km/h	19.0/17.8		19.8/18.6	
	7th km/h	28.9/27.1		30.1/28.3	
	8th km/h	39.7/37.2		41.4/38.8	
Final Drive		MG460		MG560	
Double reduction by spiral bevel and planetary gear with operator controlled hydraulically lock/unlock differential.					

OPTIONS

		MG460		MG560	
Moldboards (L×H×T)		mm-(in)		Additional wt (kg)	
3710×610×22 (146×24×0.9)		45			
4010×610×19 (158×24×0.75)		45			
4010×610×22 (158×24×0.9)		90		45	
4310×610×22 (170×24×0.9)		105			
4310×720×19 (170×28×0.75)				80	
4310×720×22 (170×28×0.9)				203	
Mid-mounted Scarifiers		wt (kg)		850	
Type V-type with 11 teeth					
Lift Above Ground	mm	430		450	
Penetration	mm	330		310	
Swath Width	mm	1,225		1,225	
Rear Ripper/Scarifier		wt (kg)		1,265	
Type Rear mounted parallel link type					
Number of Shanks 5 shanks (max.)					
Max. Lift Above Ground	mm	380		405	
Penetration	mm	465		440	
Swath Width	mm	2,200		2,200	
Shank Size (W×T)	mm	139.2×58.2		139.2×58.2	
Scarifier				Straight type	
Type					
Number of Teeth 9 teeth					
Max. Lift Above Ground	mm	620		645	
Penetration	mm	225		200	
Swath Width	mm	2,165		2,165	

		MG460		MG560	
Front Axle					
Reverse Elliot Type, Hydraulic leaning					
Oscillation (total)	deg	30		30	
Wheel Lean L/R	deg	40		40	
Ground Clearance (Front axle)	mm	570		595	
Minimum Turn Radius	mm	6,900		6,900	
Brakes					
Service Brakes	Air actuated, multi disc, oil cooled on all 4 rear wheels				
Parking Brake	Spring engaged, air disengaged, multi disc, oil cooled on T/M output shaft				
Hydraulic System					
Circuit	Closed-center, load sensing system				
Pump	Variable-displacement piston				
Capacity	cm ³ /rev	90		90	
Relief Pressure	MPa	20.6		20.6	
Steering Circuit	cm ³ /rev	25		25	
Wheels					
Tire	13.00-24-12PR (G-2)		14.00-24-12PR (G-2)		
Rim	8.00TG×24		8.00TG×24		
Moldboard					
Wear-resistant steel, with box section reinforcement with hydraulic side-shift and hydraulic blade tip					
Length×Height×Thickness	mm	3,710×610×19		4,010×610×19	
Number of Cutting Edge (L×H×T)	mm	2(1,829×152×159)		1(1,829/2,133×152×159)	
Service Capacity					
Fuel tank	ℓ	275		275	
Radiator	ℓ	50		50	
Engine Crankcase	ℓ	29		29	
Transmission	ℓ	38		38	
Rear Axle Case	ℓ	30		30	
Tandem Drive Case (each side)	ℓ	85		85	
Hydraulic Tank	ℓ	58		58	
Circle Reverse Gear	ℓ	3.5		3.5	

		MG460		MG560	
Front Dozer Blade		wt (kg)		840	
Type Pivot link type					
Width×Height	mm	2,700×900		2,700×900	
Lift Above Ground	mm	535		560	
Penetration	mm	235		210	
Front Counterweight					
1,000 kg			○		○
1,400 kg			○		○
Tires & Rims				Additional wt (kg)	
14.00-24-12ply (Rim 8.0×24)				+130	
17.5-25-12ply (Rim 14.0×25)				+315	
Accessories					
Blade slip clutch	15 kg	Odometer			
Air conditioner	70 kg	Pre-cleaner			
Front pull hook	25 kg	Rear under view mirror			
Air dryer		Reserved tank, Radiator			
Exhaust rain cap		Dual steering cylinder system			
Fire extinguisher		Emergency steering system			
Licence plate with lamp		Tire inflation kit			
Lights		Vandalism protection			
Mid-mounted working lamps		Water separator			
Rear working lamps					
Yellow rotating warning lamp					

MITSUBISHI MOTOR GRADERS
MG460/MG560

**MITSUBISHI
MOTOR GRADERS
MG460/MG560**



Mitsubishi Heavy Industries, Ltd.
General Machinery & Special Vehicle Headquarters

*The Best
to You,
from
Mitsubishi*



Standard Equipment*

- | | | | |
|--|---|---|---|
| <ul style="list-style-type: none"> • ROPS/FOPS type cab • Head lights (2) • Front directional signals (2) • Rear directional signals (2) • Tail & stop lamps (2) • Back up lamps (2) • Back up alarm buzzer • Electric hour meter • Digital electronic monitoring panel (L.C.D. meter) <ul style="list-style-type: none"> - Speedometer - Tachometer | <ul style="list-style-type: none"> - Water temperature gauge - Air pressure gauge - Fuel gauge - Articulation indicator - Parking brake indicator - High beam indicator - Directional signal indicator - Clock • Engine oil filter warning lamp • Air filter warning lamp | <ul style="list-style-type: none"> • Engine overheat warning lamp • Engine oil pressure warning lamp • Alternator not charging warning lamp • Electric horn • Air pressure alarm buzzer • Engine overheat alarm buzzer • Parking brake warning horn • Muffler for engine • Accelerator | <ul style="list-style-type: none"> • Hand throttle lever • Adjustable operators suspension seat • Adjustable control console and steering wheel • Reversible side edges and overlay end-bits for moldboard • Rear drawbar with pin • Engine compartment doors • Tool kit • Working clothes • Parts catalogue • Operation manual |
|--|---|---|---|

*Standard equipment will vary depending upon the requirements of the country of destination.

Color:
MITSUBISHI standard yellow

- Specifications and design are subject to change without notice
- The equipment shown in the photo in this catalogue contains some optional parts.

BT
EQUIPMENT
BT Equipment Pty Ltd
ABN 89 094 476 141

BRISBANE
SYDNEY
MELBOURNE
ADELAIDE
PERTH

Specifications subject to change without notice

(1300 65 8888)

Website: www.btequipment.com.au

10-14 Ashover Road, Rocklea. Qld 4106
6 Ferngrove Place, South Granville. NSW 2142
80-86 Frankston-Dandenong Road. Dandenong. Vic 3175
908 Main North Road, Mawson Lakes. SA 5095
50 Great Eastern Highway, South Guildford. WA 6055

Phone
(07) 3373 6400
(02) 9780 7200
(03) 9554 0300
(08) 8262 8292
(08) 9478 0600

Fax
(07) 3875 1680
(02) 9780 7290
(03) 9554 0398
(08) 8262 8320
(08) 9478 0688