



Heavy Duty
SCX900HD
HYDRAULIC CRAWLER CRANE

Specifications

HITACHI SUMITOMO

SCX900HD

HYDRAULIC CRAWLER CRANE

INDEX

CRAWLER CRANE	■Dimensions ■Specifications	3
	■Working Ranges	8
	■Crane Ratings	
	Main Boom in 360° Working Area	9
	Auxiliary Jib in 360° Working Area	10
	Main Boom with Auxiliary Jib in 360° Working Area	11
	■Crane Boom Construction ■Crane Jib Construction	
	■Component weights and Dimensions for Transport	12
HAMMER GRAB WORK	■General Set-up	14
	■Crane Ratings	
	Main Boom in 360° Working Area [Third drum]	
	■Hammer Grab Bucket Ratings	15
CLAMSHELL	■Dimensions ■Specifications	
	■Clamshell Bucket ■Working Ranges	16
TECHNICAL DATA	■Standard and Optional Equipment	17 to 18

Note: • "ton" or "t" implies metric tons in this catalog
• Specifications conform to the Safety Regulations for Cranes and Mobile Cranes in Japan.

■Dimensions

Unit: mm

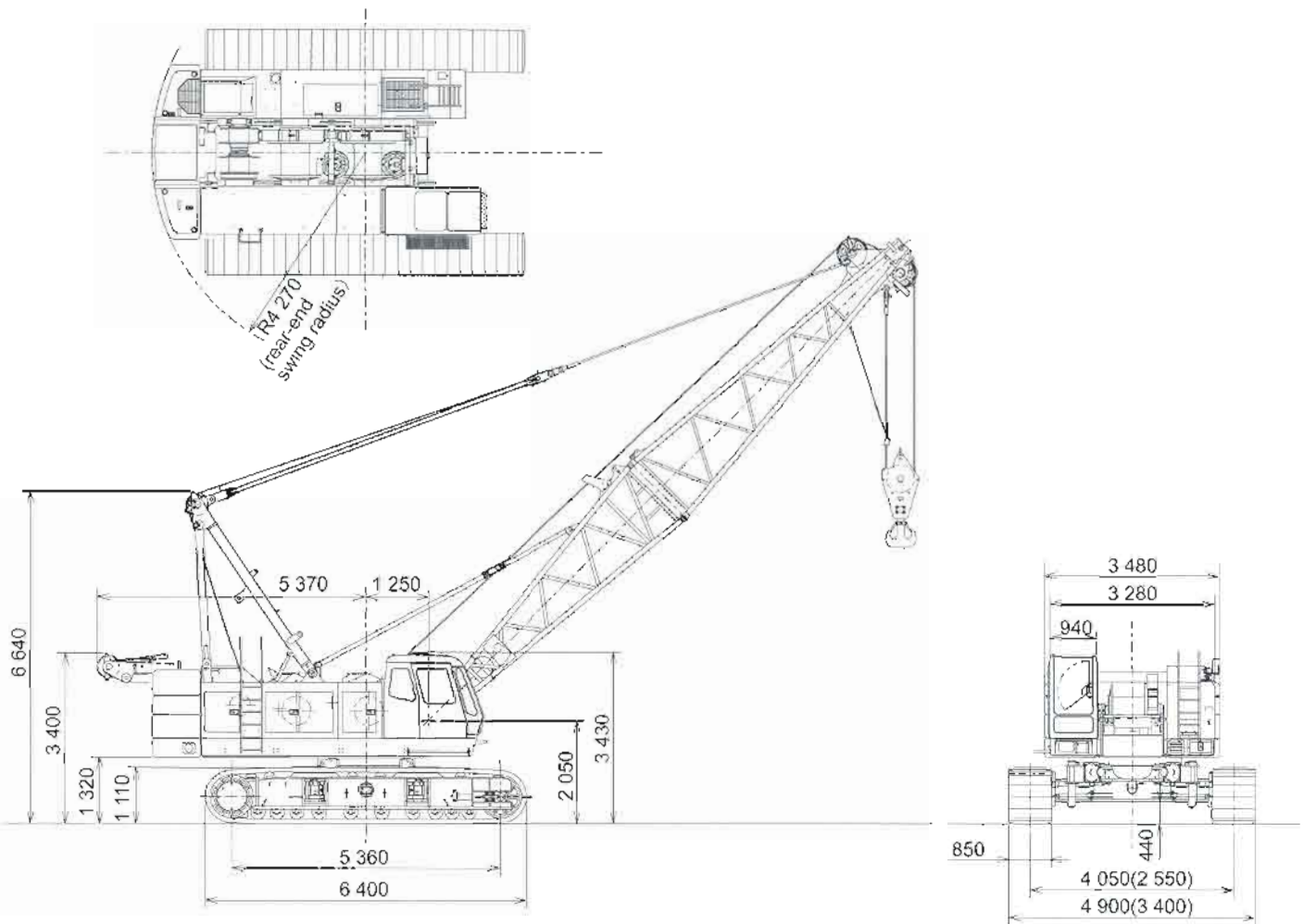

- Notes : 1. Dimensions shown in () are with side frames fully retracted.
2. Self-loading device is option.

■Specifications

(1 ton = 1 000 kg)

Maximum rated load × Working radius	ton × m	90 × 4.0
Basic boom length	m	13
Maximum boom length	m	61
Boom length with optional third drum equipped	m	13 to 25
Winch		
Maximum rated load (for crane)	ton	13
Maximum single linepull	ton	25
Line speeds		
Main hoist drum	m/min	*100/57/28
Aux. hoist drum	m/min	*100/57/28
Boom hoist drum	m/min	*64
Optional third hoist drum	m/min	*64
Swing speed	min ⁻¹ (rpm)	3.5(3.5)
Travel speed High/Low	km/h	1.5/1.0
Gradeability	%(°)	30(16)
Engine model		Mitsubishi 6D24-TL
Rated horsepower	kw/min ⁻¹ (PS/rpm)	220/2 000 (300/2 000)
Ground pressure	kPa (kgf/cm ²)	89.5 (0.91)
Operating weight	ton	88.9
(Equipped with 13 m boom and 90 000 kg capacity hook)		

- Notes : 1. Data expressed above are SI units, followed by conventional units in ()
2. Line speeds will vary with the load.

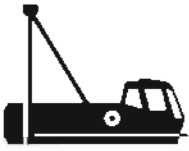

SUPERSTRUCTURE



Engine

Model	Mitsubishi 6D24-TL
Type	Water-cooled, 4-cycle, 6-cylinder, direct fuel injection type diesel engine
Rated horsepower	220 kW (300 PS) at 2 000 min ⁻¹ (2 000 rpm)
Maximum torque	1 230 N·m (125.4 kgf m) at 1 400 min ⁻¹ (1 400 rpm)
Piston displacement	11.94 L
Fuel tank capacity	415 L
Electric system	DC 24 V



Main and Auxiliary Hoist Mechanism

- The SCX900HD is equipped with dual hoist mechanisms, each consisting of independent main and auxiliary hoist drums driven by a hydraulic motor.
- Hoisting and lowering the load is achieved by forward/reverse rotation of the hydraulic motor.
- Power lowering is carried out with a hydraulic brake.
- Hoisting and lowering can be carried out at three speeds-fast, medium and slow-to suit job requirements.
- Each drum is fitted with a friction band-type brake. This allows free fall (rapid lowering) of the hook.
- Main and auxiliary hoist drums are each fitted with a pawl-type drum lock to positively hold the load in the air.
- The drum brake is an external contracting friction band-type using durable non-asbestos lining.
- The brake is controlled by the hydraulic servo system to reduce control force. Two brake modes are available; auto brake or free fall.



Boom Hoist Mechanism

- Boom hoisting/lowering is done by forward/reverse rotation of a hydraulic motor. Boom lowering is made by power lowering through a hydraulic brake.
- Both hydraulic brake and spring-set/hydraulic-released multiplate disc type brake offer positive stopping of the boom. When the boom is hoisted or lowered, brakes are automatically released.
- Drum pawl lock is manually controlled from operator's seat.



Swing Mechanism

- Independent operation
- Driven by two hydraulic motors through reduction gear. Swing speeds are freely controllable from zero to maximum speed with a single lever.

Swing Brake

The disc-type swing brake can be hydraulically applied by the brake switch on the swing lever.

Swing Lock

Manual mechanical-lock with a rod tip engaged in the holder of the track frame for transportation.

Swing Circle

Single-row shear-type ball bearing with heat-treated internal gear.



Revolving Frame

All welded steel construction, stress-relieved, precision-machined for rigidity and strength

Gantry

Lowerable for transportation

Counterweight

Welded structure, total weight	30 400 kg
Consisting of 4 sections :	One 8 580 kg
	One 7 350 kg
	One 6 610 kg
	One 7 850 kg

HYDRAULIC SYSTEM



Boom

Tubular Chord Crane Boom

1 500 mm wide by 1 500 mm deep at connection, lattice construction using high-tensile steel tubular chords

- Basic boom Total length 13.0 m, 2-piece construction; upper section 6.5 m and lower section 6.5 m
- Boom point Offset boom point, 4 sheaves (560 mm PCD) mounted on anti-friction bearings on boom top
- Boom inserts..... 3.0 m, 6.0 m and 9.0 m long available
- Connection type..... Pin-connected
- Boom backstop..... Dual-rail, telescopic tubular construction with spring damper
- Boom hoist bridle... Serves as connection between pendants and boom hoist wire rope reeving, equipped with 6 sheaves (420 mm PCD) for 12-part boom hoist wire rope reeving

Auxiliary Jib (Optional)

Attachable to the main boom top to hoist the light load quickly with a single rope.



Operator's Cab

All-weather, well-ventilated, roomy operator's cab with good visibility. The independent cab is insulated against noise and vibration. Sliding, fold-in windshield swings up and stores in roof. Adjustable reclining seat

- 3 variable displacement piston pumps allow both independent and combined operations of all functions.
- Variable displacement piston pumps control working speeds, and make effective use of engine horsepower.

	Pump-1	Pump-2
Type of pump	Variable displacement	
Pressure setting	29.4 MPa (300 kgf/cm ²)	29.4 MPa (300 kgf/cm ²)
Max. Oil flow*	236 L/min	236 L/min

	Pump-3	Pump-4
Type of pump	Variable displacement	Gear
Pressure setting	27.5 MPa (280 kgf/cm ²)	4.9 MPa (50 kgf/cm ²)
Max. Oil flow*	148 L/min	36 L/min

*with non-loaded condition

Main and Auxiliary Hoist Motors

Swashplate-type axial piston motors with counterbalance valves

Boom Hoist Motor

Bent axis motor with counterbalance valve

Swing Motor

Swashplate-type axial piston motor

Travel Motors

Swashplate-type axial piston motors with brake valve and spring-set/hydraulic-released multiplate disc brake

Relief and Brake Valves

- Each hydraulic circuit incorporates large-capacity relief valves to protect circuit from overload and shock load.
- Counterbalance valves, provided for hoist motor, compensate load lowering and prevent accidental load drop if hydraulic power is suddenly reduced.
- Brake valves (consisting of relief valve and counterbalance valve) are provided for travel circuit

Pressure Settings

Main Circuit

- Main relief valves
 - Hoist (main and aux.) 29.4 Mpa (300 kgf/cm²)
 - Swing 27.5 Mpa (280 kgf/cm²)
- Overload relief valves
 - Hoist (main and aux.) circuits 30.8 Mpa (315 kgf/cm²)
 - Boom hoist circuit. 31.4 Mpa (320 kgf/cm²)
 - Travel circuit... 29.4 Mpa (300 kgf/cm²)

Pilot Circuit

- Main relief valve 4.9 Mpa (50 kgf/cm²)

Line Filters

High-filtration 10 μm full-flow filter element is incorporated in the return line. Pilot filter and suction filter are provided in each circuit.



UNDERCARRIAGE

Traction mechanism

- Each track is driven by a swashplate-type axial piston motor through reduction gear. This mechanism allows counter-rotation of tracks for maneuverability in close quarters.
- When the lever is in neutral position, both hydraulic brake and spring-set/hydraulic-released multiplate disc brake are automatically applied for stopping.

Track Frame

All-welded, stress-relieved, box-section construction

Side Frames

Side frames of all-welded construction can be retracted for transportation.

Self-Loading Device (Optional)

With the self-loading device (basic machine jack-up device and side frame extend cylinders), the basic machine can be jacked up and loaded on to a trailer, and both side frames can be removed. Travel motor piping is connected via self-seal couplings for quick disconnection.

Track Shoes

Heat-treated alloy steel castings with induction-hardened roller path and driving lugs

No. of upper rollers (each side)	4
No. of lower rollers (each side).....	10
No. of track shoes (each side)	55
Shoe width	850 mm



CONTROLS

Boom, Main and Auxiliary Hoist, Swing and Travel

Remote controlled hydraulic servo. Working speed can be precisely controlled according to lever stroke.

• Electric Accelerator Grip

Engine horsepower can be controlled according to job needs by electric finger-touch grip atop the swing lever, accelerator lever and accelerator pedal.

• Monitor Telling Machine Conditions

With the monitor, the operator can check, at a glance, engine oil pressure, water temperature and fuel level, as well as levels of hydraulic oil, engine oil and coolant. The red light turns on and the buzzer sounds in the event of an abnormality.



SAFETY DEVICE

Boom Angle Indicator

Mechanical-type boom angle indicator is provided at boom foot.

Counterbalance Valves (Brake Valves)

Counterbalance valves are each incorporated in travel motors, boom hoist motor, and main and auxiliary hoist motors. If the hydraulic line is broken, this valve is automatically actuated to prevent motor rotation.

Spring-Set/Hydraulic-Released Multiplate Disc Type Travel Brakes

Swing Lock and Swing Parking Brake

Drum Locks (Electric Type)

A pawl-type drum locks, provided at main drum, auxiliary drum and boom drum, are automatically applied when the engine key is set to OFF or ACC position.

Lever Locks

Main and auxiliary hoist levers, boom hoist lever, and travel levers are each fitted with lock mechanisms to prevent mishandling.

Devices for Crane Operation

• Moment Limiter

On the moment limiter, analog displays and pictorial load indications are functionally arranged for easy reading.

• Hook Overhoist Prevention Device

When the hook reaches its hoist limit, the bell sounds and the auto-stop automatically actuates at the same time.

• Boom Overhoist Prevention Device

When the boom reaches its angle limit, the buzzer alarm sounds and boom hoisting automatically stops at the same time. The telescopic-type boom backstop is also provided.

• Secondary Boom Overhoist Prevention Device

In addition to the hook overhoist prevention device and boom overhoist prevention device, the secondary boom overhoist prevention device is provided. It actuates at a boom angle of 82° to avoid overhoisting of both the boom and/or hook.

• Pilot Control Shut-off Lever

The pilot control shut-off lever shuts out the hydraulic pilot pressure to pilot control valves. With the pilot control shut-off lever in the LOCK position, the machine will not operate even if the lever is accidentally shifted.

• Fail-safe mechanism

The related movements stop automatically if an electric wire is broken or an electric device fails.



SERVICE REFILL CAPACITIES

	Liter
Fuel tank	415
Engine coolant	47
Engine oil	45
Pump transmission	2
Boom hoist reduction device	10
Winch hoist reduction device	19.5 × 2
Swing reduction device	17 × 2
Travel final device	25 × 2
Hydraulic system , including tank capacity	335
Hydraulic tank	255

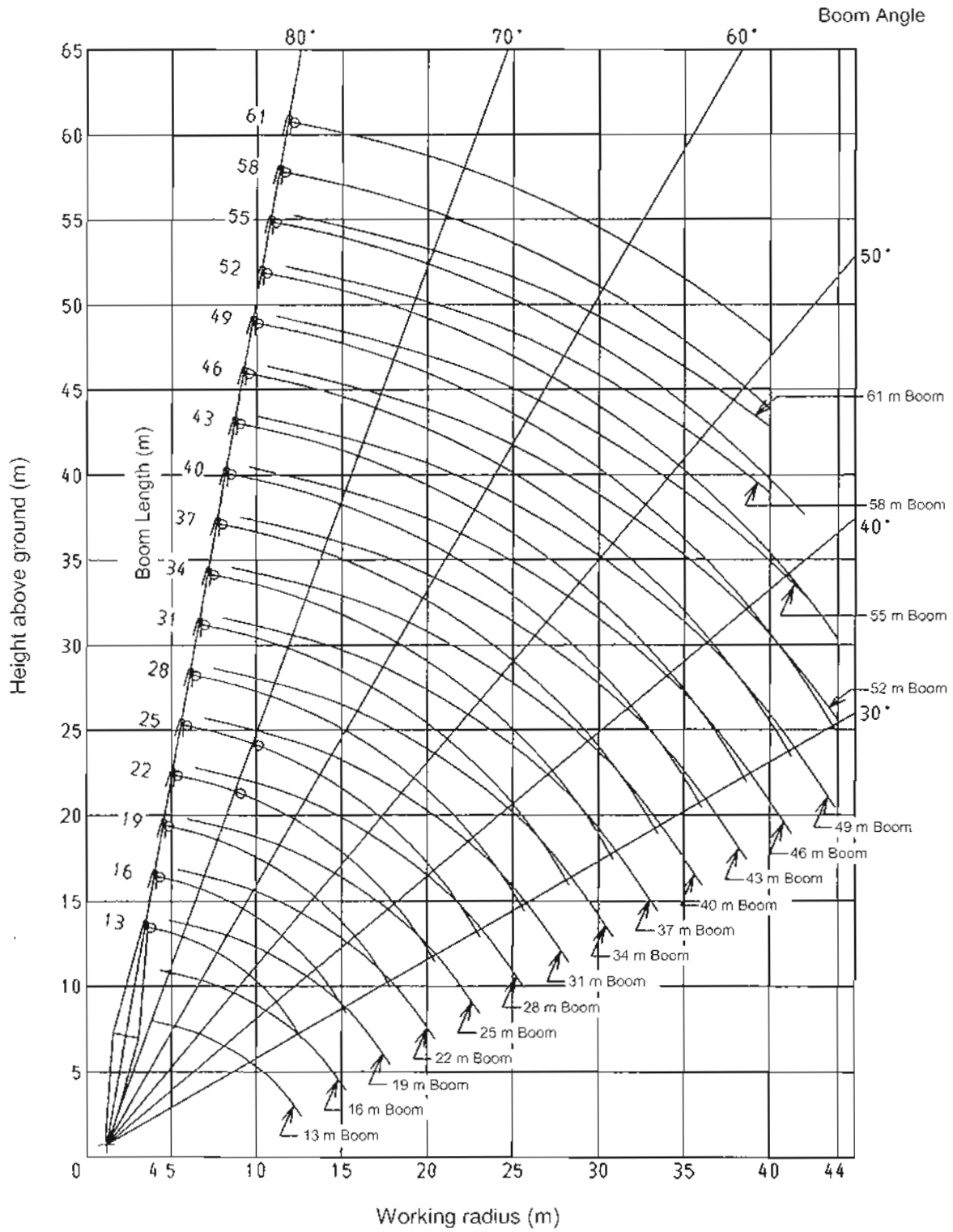

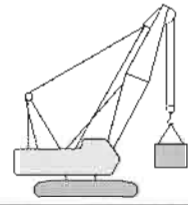

■ Crane Ratings (Main Boom in 360° Working Area)

Unit: ton

Working Radius (m)	Boom Length (m)								
	13	16	19	22	25	28	31	34	37
4.0	90.00								
4.5	80.50	4.6×78.45							
5.0	70.80	70.60	5.1×68.25						
5.5	60.85	60.65	60.55	5.7×57.25					
6.0	53.35	53.10	53.00	52.95	6.2×50.30				
6.5	47.40	47.20	47.05	47.00	46.90	6.7×44.80			
7.0	42.65	42.40	42.25	42.20	42.10	42.05	7.3×39.45	7.8×35.75	
8.0	35.45	35.20	35.05	35.00	34.85	34.80	34.65	34.50	8.4×32.15
9.0	30.25	30.00	29.85	29.75	29.65	29.55	29.40	29.30	29.25
10.0	26.35	26.05	25.90	25.85	25.70	25.65	25.45	25.35	25.25
12.0	20.50	20.55	20.35	20.30	20.15	20.05	19.90	19.75	19.70
14.0	12.6×18.30	16.85	16.65	16.55	16.40	16.35	16.15	16.05	15.95
16.0		15.2×14.90	14.05	13.90	13.75	13.70	13.50	13.35	13.30
18.0			17.8×12.25	11.95	11.80	11.70	11.50	11.35	11.30
20.0				10.40	10.25	10.15	9.95	9.80	9.70
22.0				20.4×10.15	9.00	8.90	8.70	8.55	8.45
24.0					23.0×8.50	7.90	7.70	7.55	7.45
26.0						25.6×7.20	6.85	6.70	6.60
28.0							6.15	6.00	5.90
30.0							28.2×6.10	5.40	5.25
32.0								30.8×5.20	4.75
33.4									4.45

Working Radius (m)	Boom Length (m)							
	40	43	46	49	52	55	58	61
8.9	29.50							
9.0	29.05	9.5×26.85						
10.0	25.10	25.00	24.85	10.6×22.85	11.1×21.25	11.7×19.60		
12.0	19.55	19.40	19.25	19.20	19.05	18.90	12.2×17.15	12.8×14.90
14.0	15.80	15.65	15.50	15.45	15.30	15.15	15.00	14.40
16.0	13.10	12.95	12.85	12.75	12.60	12.45	12.30	12.15
18.0	11.10	10.95	10.80	10.75	10.60	10.45	10.30	10.10
20.0	9.55	9.40	9.25	9.15	9.05	8.90	8.70	8.55
22.0	8.30	8.15	8.00	7.90	7.75	7.60	7.45	7.30
24.0	7.25	7.10	6.95	6.90	6.75	6.60	6.40	6.25
26.0	6.40	6.25	6.10	6.00	5.90	5.75	5.55	5.35
28.0	5.70	5.55	5.40	5.30	5.15	4.95	4.75	4.50
30.0	5.10	4.95	4.80	4.65	4.45	4.25	4.05	3.80
32.0	4.55	4.40	4.20	4.05	3.85	3.65	3.45	3.20
34.0	4.10	3.90	3.70	3.55	3.35	3.15	2.90	2.70
36.0	3.60	3.45	3.25	3.05	2.90	2.70	2.45	2.25
38.0		3.05	2.85	2.65	2.50	2.30	2.05	1.80
40.0		38.6×2.90	2.50	2.30	2.10	1.90	1.70	39.7×1.50
42.0			41.2×2.30	2.00	1.80	1.60	41.1×1.50	
44.0				43.8×1.70	1.50	42.6×1.50		

Notes 1. The rated loads shown do not exceed 78% of tipping load with the machine on firm level ground, and are not less than 1.15 times over-front stability stipulated by the mobile crane construction standards

2. The load to be actually lifted will be the rated load shown minus the weight of all lifting attachments such as a hook.

3. Working radius is the horizontal distance from the swing center to the center of gravity of a lifted load

4. Figures described as ○●×○● in the tables indicate working radius (m) × rated load (ton)

5. The counterweight is 30.4 ton.

6. Be sure to fully extend the side frames before operating the machine.

7. Correlation among the number of rope reevings, maximum rated loads and hook weights are shown in the table below.

Hook Capacity (ton)	Hook Weight (ton)	Maximum Rated Load (ton)							
		8 Rope reevings	7 Rope reevings	6 Rope reevings	5 Rope reevings	4 Rope reevings	3 Rope reevings	2 Rope reevings	1 Rope reeving
90	0.97	90	85	73	61	49	—	—	—
45	0.62	—	—	—	—	45	37	25	—
25	0.73	—	—	—	—	—	—	25	—
13	0.50	—	—	—	—	—	—	—	13

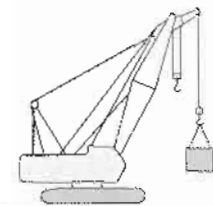

■ Crane Ratings (Auxiliary Jib in 360° Working Area)

Unit: ton

Working Radius (m)	Boom Length (m)							
	13	16	19	22	25	28	31	34
4.8	13.00							
5.0	13.00	5.3×13.00						
5.5	13.00	13.00	5.9×13.00					
6.0	13.00	13.00	13.00	6.4×13.00				
6.5	13.00	13.00	13.00	13.00				
7.0	13.00	13.00	13.00	13.00	13.00	7.5×13.00		
8.0	13.00	13.00	13.00	13.00	13.00	13.00	13.00	8.6×13.00
9.0	13.00	13.00	13.00	13.00	13.00	13.00	13.00	13.00
10.0	13.00	13.00	13.00	13.00	13.00	13.00	13.00	13.00
12.0	13.00	13.00	13.00	13.00	13.00	13.00	13.00	13.00
14.0	13.00	13.00	13.00	13.00	13.00	13.00	13.00	13.00
16.0		13.00	13.00	13.00	13.00	13.00	13.00	13.00
18.0		16.6×13.00	12.10	11.95	11.75	11.65	11.45	11.35
20.0			19.2×10.95	10.25	10.05	9.95	9.75	9.60
22.0				21.8×9.15	8.80	8.70	8.50	8.35
24.0					7.80	7.70	7.50	7.30
26.0					24.4×7.65	6.85	6.65	6.45
28.0						27.0×6.50	5.95	5.75
30.0							29.6×5.45	5.15
32.0								4.65
32.2								4.60

Working Radius (m)	Boom Length (m)						
	37	40	43	46	49	52	55
9.1	13.00	9.7×13.00					
10.0	13.00	13.00	10.2×13.00	10.8×13.00	11.3×13.00	11.9×13.00	
12.0	13.00	13.00	13.00	13.00	13.00	13.00	12.4×13.00
14.0	13.00	13.00	13.00	13.00	13.00	13.00	13.00
16.0	13.00	13.00	12.90	12.85	12.65	12.50	12.35
18.0	11.20	10.90	10.75	10.60	10.50	10.35	10.20
20.0	9.50	9.30	9.15	9.00	8.95	8.80	8.65
22.0	8.25	8.05	7.90	7.75	7.65	7.50	7.35
24.0	7.20	7.05	6.90	6.70	6.65	6.45	6.30
26.0	6.35	6.20	6.00	5.85	5.75	5.60	5.45
28.0	5.65	5.45	5.30	5.15	5.00	4.80	4.60
30.0	5.05	4.85	4.65	4.45	4.30	4.10	3.90
32.0	4.50	4.30	4.05	3.85	3.70	3.50	3.30
34.0	4.00	3.75	3.55	3.35	3.20	3.00	2.80
36.0	34.8×3.85	3.30	3.10	2.90	2.75	2.55	2.30
38.0		37.4×3.05	2.70	2.50	2.30	2.10	1.90
40.0			2.35	2.15	1.95	1.75	1.55
42.0				1.85	1.65	1.6×1.50	1.5×1.50
43.0				42.6×1.75	1.50		

- Notes:
1. The rated loads shown do not exceed 78% of tipping load with the machine on firm level ground, and are not less than 1.15 times over-front stability stipulated by the mobile crane construction standards.
 2. The load to be actually lifted will be the rated load shown minus the weight of all lifting attachments such as a hook.
 3. Working radius is the horizontal distance from the swing center to the center of gravity of a lifted load.
 4. Figures described as ○○×○○ in the tables indicate working radius (m) × rated load (ton).
 5. The counterweight is 30.4 ton.
 6. Be sure to fully extend the side frames before operating the machine.
 7. Correlation among the number of rope reevings, maximum rated loads and hook weights are shown in the table below.

	Hook Capacity (ton)	Hook Weight (ton)
Main Hook	90	0.97
	45	0.62
	25	0.73
Aux. Hook	13	0.50

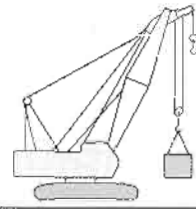

■ Crane Ratings (Main Boom with Auxiliary Jib in 360° Working Area)

Unit: ton

Working Radius (m)	Boom Length (m)							
	13	16	19	22	25	28	31	34
4.0	89.65							
4.5	80.15	4 6×78.10						
5.0	70.40	70.20	5.1×67.90					
5.5	60.50	60.25	60.15	5.7×56.85				
6.0	52.95	52.70	52.60	52.55	6 2×49.90			
6.5	47.05	46.80	46.65	46.60	46.50	6 7×44.40		
7.0	42.25	42.00	41.90	41.80	41.70	41.65	7 3×39.00	7 8×35.35
8.0	35.05	34.80	34.65	34.60	34.45	34.40	34.20	34.10
9.0	29.90	29.60	29.45	29.40	29.25	29.20	29.00	28.85
10.0	25.95	25.70	25.55	25.45	25.30	25.25	25.05	24.90
12.0	20.00	20.15	20.00	19.90	19.75	19.65	19.50	19.35
14.0	12.6×17.80	16.50	16.30	16.20	16.05	15.95	15.75	15.60
16.0		15.2×14.40	13.70	13.55	13.40	13.30	13.10	12.95
18.0			17.8×11.85	11.60	11.40	11.30	11.10	10.95
20.0				10.05	9.85	9.75	9.55	9.40
22.0				20.4×9.80	8.65	8.50	8.30	8.15
24.0					23.0×8.15	7.55	7.30	7.15
26.0						25.6×6.85	6.50	6.30
28.0							5.80	5.60
30.0							28.2×5.75	5.00
30.8								4.80

Working Radius (m)	Boom Length (m)						
	37	40	43	46	49	52	55
8.4	31.75	8.9×29.10					
9.0	28.80	28.65	9.5×26.40				
10.0	24.85	24.70	24.55	24.40	10.6×22.40	11.1×20.80	11.7×19.15
12.0	19.30	19.10	18.95	18.80	18.75	18.60	18.45
14.0	15.55	15.35	15.20	15.05	15.00	14.85	14.70
16.0	12.90	12.70	12.55	12.40	12.30	12.15	12.00
18.0	10.85	10.70	10.55	10.35	10.30	10.15	10.00
20.0	9.30	9.10	8.95	8.80	8.70	8.55	8.40
22.0	8.05	7.85	7.70	7.55	7.45	7.30	7.15
24.0	7.05	6.85	6.70	6.55	6.45	6.30	6.15
26.0	6.20	6.00	5.85	5.70	5.60	5.45	5.25
28.0	5.50	5.30	5.15	4.95	4.85	4.70	4.50
30.0	4.90	4.70	4.55	4.35	4.20	4.00	3.80
32.0	4.40	4.15	4.00	3.85	3.60	3.40	3.20
34.0	33.4×3.90	3.70	3.45	3.35	3.10	2.90	2.65
36.0		3.10	3.05	2.90	2.85	2.40	2.20
38.0			2.55	2.50	2.25	2.00	1.80
40.0			38.6×2.35	2.15	1.90	1.65	39.7×1.50
42.0				41.2×1.80	1.55	41.0×1.50	
42.3					1.50		

- Notes: 1. The rated loads shown do not exceed 78% of tipping load with the machine on firm level ground, and are not less than 1.15 times over-front stability stipulated by the mobile crane construction standards.
 2. The load to be actually lifted will be the rated load shown minus the weight of all lifting attachments such as a hook.
 Aux Hook Capacity 13 ton, Aux Hook Weight 0.50 ton
 3. Working radius is the horizontal distance from the swing center to the center of gravity of a lifted load
 4. Figures described as ○○×○○ in the tables indicate working radius (m) × rated load (ton)
 5. The counterweight is 30.4 ton
 6. Be sure to fully extend the side frames before operating the machine
 7. Correlation among the number of rope reevings, maximum rated loads and hook weights are shown in the table below.

Hook Capacity (ton)	Hook Weight (ton)	Maximum Rated Load (ton)						
		8 Rope reevings	7 Rope reevings	6 Rope reevings	5 Rope reevings	4 Rope reevings	3 Rope reevings	2 Rope reevings
90	0.97	90	85	73	61	49	—	—
45	0.62	—	—	—	—	45	37	25
25	0.73	—	—	—	—	—	—	25

■ General Set-up

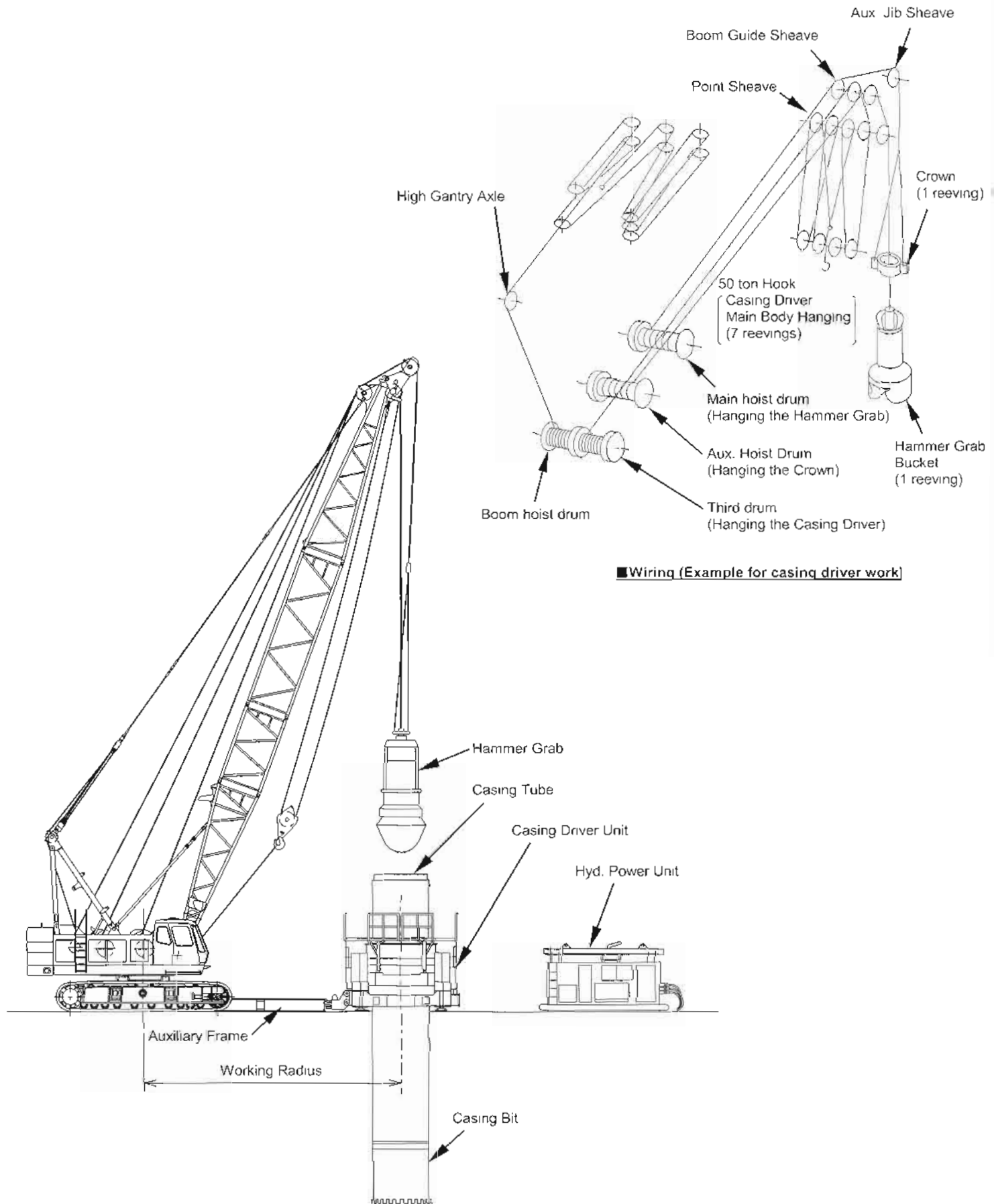

■ Crane Ratings (Main Boom in 360° Working Area) [Third drum]

Unit: ton

Working Radius (m)	Boom Length (m)				
	13	16	19	22	25
4.0	50.00				
4.5	50.00	4.6m×50.00t			
5.0	50.00	50.00	5.1m×50.00t		
5.5	50.00	50.00	50.00	5.7m×50.00t	
6.0	50.00	50.00	50.00	50.00	6.2m×50.00t
6.5	47.40	47.20	47.05	47.00	46.90
7.0	42.65	42.40	42.25	42.20	42.10
8.0	35.45	35.20	35.05	35.00	34.85
9.0	30.25	30.00	29.85	29.75	29.65
10.0	26.35	26.05	25.90	25.85	25.70
12.0	20.60	20.55	20.35	20.30	20.15
14.0	12.6m×18.40t	16.85	16.65	16.55	16.40
16.0		15.2m×14.90t	14.05	13.90	13.75
18.0			17.8m×12.25t	11.95	11.80
20.0				10.40	10.25
22.0				20.4m×10.15t	9.00
23.0					8.50

- Notes
- 1 The rated loads shown do not exceed 78% of tipping load with the machine on firm level ground, and are not less than 1.15 times over-front stability stipulated by the mobile crane construction standards
 - 2 The load to be actually lifted will be the rated load shown minus the weight of all lifting attachments such as a hook
 - 3 Working radius is the horizontal distance from the swing center to the center of gravity of a lifted load.
 - 4 The counterweight is 30.4 ton
 - 5 Be sure to fully extend the side frames before operating the machine.
 - 6 Correlation among the number of rope reevings, maximum rated loads and hook weights are shown in the table below

Hook Capacity (ton)	Maximum Rated Load (ton)						
	7 Rope reevings	6 Rope reevings	5 Rope reevings	4 Rope reevings	3 Rope reevings	2 Rope reevings	1 Rope reeving
50	50.0	45.0	37.5	30.0	22.5	15.0	—

■ Hammer Grab Bucket Ratings

Unit: ton

Working Radius (m)	Boom Length (m)				
	13	16	19	22	25
7.3	12.00				
8.0	12.00	8.6m×12.00t			
9.0	12.00	12.00	9.9m×12.00t		
10.0	12.00	12.00	12.00		
11.0	12.00	12.00	12.00	11.1m×12.00t	
12.0	12.00	12.00	12.00	12.00	12.4m×12.00t
13.0	12.4m×12.00t	12.00	12.00	12.00	12.00
14.0		12.00	12.00	12.00	12.00
15.0		14.8m×12.00t	12.00	12.00	12.00
16.0			12.00	12.00	12.00
17.0			11.70	11.60	11.40
18.0			17.3m×11.40t	10.75	10.60
19.0				10.05	9.85
20.0				19.8m×9.50t	9.20
21.0					8.60
22.0					8.10
22.2					7.95

- Notes
- 1 Working radius is the horizontal distance from the swing center to the center of gravity of lifted load.
 - 2 The rated loads shown are upper limits determined by the following equation. Please select a bucket in such a manner that its rated load does not exceed the rated load shown above, according to kinds of the loads handled.

$$\text{Rated load} = \text{Bucket capacity (m}^3\text{)} \times \text{Specific gravity of load (ton/m}^3\text{)} + \text{Bucket weight (ton)}$$
 Be careful that brake will be overheated if the bucket is too heavy even within the rated loads
 - 3 Maximum bucket weights is 8.0 ton.
 - 4 Be sure to fully extend the side frames before operating the machine.
 - 5 The counterweight is 30.4 ton

■ Dimensions

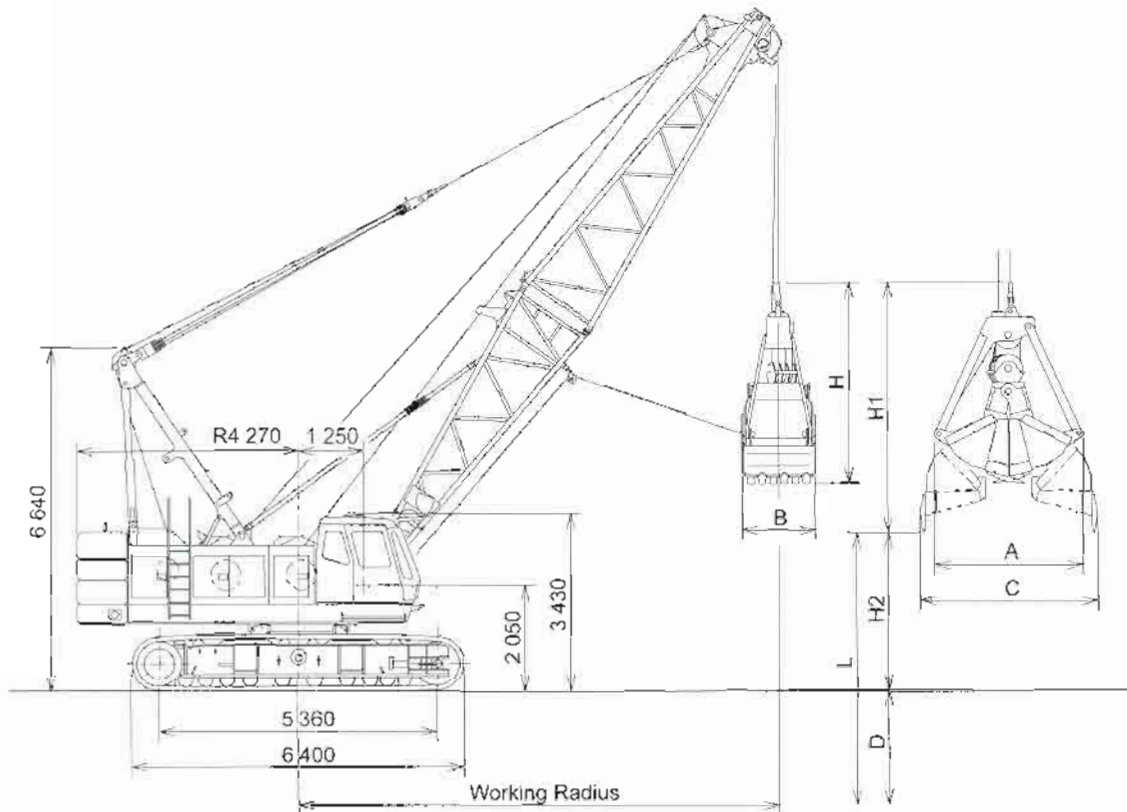

■ Specifications

Bucket capacity	m ³	3.0
Allowable clamshell gross weight	ton	12.0
Boom length	m	13 to 22
Max. digging depth	m	36
line speeds		
Suspend line	m/min	*100/57/28
Open/close line	m/min	*100/57/28
Boom hoist/upper line	m/min	*64
Boom hoist/lower line	m/min	64
Ground pressure	kPa (kgf/cm ²)	95.0 (0.97)
Operating weight	ton	94.4 (13 m boom + 3.0 m ³ bucket)

- Notes: 1. Data is expressed in SI units, followed by conventional units in ()
 2. *Line speeds will vary with the load.
 3. Other specifications, not shown, are similar to those for the crawler crane.

■ Clamshell Bucket

Capacity (m ³)	Weight (ton)	A (mm)	B (mm)	C (mm)	H (mm)	H1 (mm)
3.0	6.5	2 980	1 650	3 500	3 550	4 550

■ Working Ranges

Boom length	im	13				16				19				22			
		35	45	55	65	35	45	55	65	35	45	55	65	35	45	55	65
Working radius	im	12.4	11.0	9.3	7.3	14.8	13.1	11.0	8.6	17.3	15.2	12.7	9.9	19.8	17.3	14.4	11.1
Rated load	ton	12	12	12	12	12	12	12	12	11	12	12	12	9.5	11	12	12
Lift $L=D+H2$	m	38.3	40.1	41.6	42.5	40.1	42.2	44.1	45.5	41.8	44.4	46.5	48.2	43.5	46.5	49.0	51.0
Max. digging depth D	m	36															
Dumping height H2	m	2.3	4.1	5.6	6.5	4.1	6.2	8.1	9.5	5.8	8.4	10.5	12.2	7.5	10.5	13.0	15.0

- Notes: 1. The rated loads shown are upper limits determined by the following equation. Please select a bucket in such a manner that its rated load does not exceed the rated load shown above, according to kinds of the loads handled.
 Rated load = Bucket capacity (m³) × Specific gravity of load (ton/m³) + Bucket weight (ton)
 Be careful that brake will be overheated if the bucket is too heavy even within the rated loads
 2. Working radius is the horizontal distance from the swing center to the center of gravity of lifted load.
 3. The bucket weight is 6.5 ton max.
 4. The counterweight is 30.4 ton.
 5. Be sure to fully extend the side frames before operating the machine.
 6. Free fall using brake will vary with operating conditions such as bucket weight and work cycle, but its height should be within 10 m

■ Standard Equipment

BASIC MACHINE

Undercarriage

- Crawler-type undercarriage (with 850 mm shoes)

Uppersuperstructure

- | | |
|--|--|
| <ul style="list-style-type: none"> ● Front lights (2 lights) ● Rearview mirrors (left and right) ● Centralized lubrication system (for gantry and swing circle) ● Electric refuel device ● Under-cover (at superstructure bottom) | <ul style="list-style-type: none"> ● Cab climbing steps ● Ultra slow speed controller ● Drum rotation sensing system ● 30.4 ton counterweight ● Standard tool kit |
|--|--|

Cab

- | | |
|--|---|
| <ul style="list-style-type: none"> ● Intermittent-wipers (front and roof windows) ● Washers (front and roof windows) ● Rolled sunshade (roof window) ● Sunvisor ● Floor mat ● Room light | <ul style="list-style-type: none"> ● Auto-tuning clock radio (AM/FM) ● Cigarette lighter ● Ashtray ● Brake mode selector switch ● Electric tilt-type stand |
|--|---|

Safety Devices

- | | |
|--|---|
| <ul style="list-style-type: none"> ● Swing lock ● Drum pawl lock (main and auxiliary hoist, and boom hoist) ● Swing alarm | <ul style="list-style-type: none"> ● Fail safe brake system ● Pilot control shut-off lever ● Before-work check monitor |
|--|---|

STANDARD EQUIPMENT FOR RESPECTIVE FRONT ATTACHMENTS

Crane

- | | |
|--|---|
| <ul style="list-style-type: none"> ● 13 m basic boom (lower 6.5 m, upper 6.5 m) ● Boom stop ● Boom angle indicator ● 90 ton hook ● Main hoist rope (28 mm dia. × 200 m) | <ul style="list-style-type: none"> ● Boom hoist rope (20 mm dia. × 170 m) ● Moment limiter ● Overhoist prevention devices (Including secondary safety device for main hook and boom hoist) |
|--|---|

Clamshell

- | | |
|---|---|
| <ul style="list-style-type: none"> ● 13 m basic boom (lower 6.5 m, upper 6.5 m) ● Boom stop ● Boom angle indicator ● Open/close and suspend rope disengagement prevention device (for tubular chord boom) ● Open/close rope (28 mm dia. × 82 m)* | <ul style="list-style-type: none"> ● Suspend rope (28 mm dia. × 70 m)* ● Hydraulic tagline (10 mm dia. × 55 m rope included) ● Boom hoist rope (20 mm dia. × 170 m) <p>* Two lengths of open/close and suspend ropes are determined based on 22 m boom length and 12 m digging depth</p> |
|---|---|

■ Standard and Optional Equipment

○:Standard equipment ●:Optional equipment — :Not recommended

Undercarriage	CRANE	CLAMSHELL
Self-Loading device : Basic machine jack-up device (including side frame extend cylinders)	●	●
Superstructure		
Drum cooler (for aux. drum)	—	●
Side walk (folded type)	—	●
Side walk (fixed type with handrails)	●	●
Fuel double element	●	●
Engine air cleaner double element	●	●
Cab		
AM/FM radio	○	○
Fan	●	●
Loudspeaker	●	●
Air conditioner	●	●
Heater	●	●
Safety Device		
Boom lower limiter	—	●
Foam type level (in cab)	●	●
Bucket overhoist prevention device	—	●
Moment limiter external indicator	●	—
Gangway on boom	●	●
Front Attachment for Crane		
90 ton hook	○	—
45 ton hook	●	—
25 ton hook	●	—
13 ton hook	●	—
3 m boom insert	●	●
6 m boom insert	●	●
9 m boom insert	●	●
Aux. jib assembly [aux. jib, aux. jib hook overhoist prevention device, aux. jib rope (28 mm dia. × 125 m), 13 ton hook]	●	—
Third drum (Free fall type)	●	—
Rope for third drum (22 mm dia. × 205 m)	●	—
50 ton hook for third drum	●	—
Aux. jib for hammer grab bucket	●	—
Front Attachment for Clamshell		
3.0 m ³ clamshell bucket	—	●
Open/close and suspend ropes	—	●
Hydraulic tagline	—	●

[The page contains extremely faint, illegible text that appears to be a scan of a document with very low contrast or a very light font. The text is arranged in approximately 25 horizontal lines across the page.]



Specifications subject to change without notice

(1300 65 8888)

Website: www.btequipment.com.au

		Phone	Fax
BRISBANE	10-14 Ashover Road, Rocklea. Qld 4106	(07) 3373 6400	(07) 3875 1680
SYDNEY	6 Ferngrove Place, South Granville. NSW 2142	(02) 9780 7200	(02) 9780 7290
MELBOURNE	80-86 Frankston-Dandenong Road, Dandenong. Vic 3175	(03) 9554 0300	(03) 9554 0398
ADELAIDE	908 Main North Road, Mawson Lakes. SA 5095	(08) 8262 8292	(08) 8262 8320
PERTH	50 Great Eastern Highway, South Guildford. WA 6055	(08) 9478 0600	(08) 9478 0688